

ME20F-SH

Multi-Purpose Camera
Instruction Manual

Caméra polyvalente
Mode d'emploi

English

Français



Important Usage Instructions

2

WARNING

TO REDUCE THE RISK OF ELECTRIC SHOCK AND TO REDUCE ANNOYING INTERFERENCE, USE THE RECOMMENDED ACCESSORIES ONLY.

COPYRIGHT WARNING:

Unauthorized recording of copyrighted materials may infringe on the rights of copyright owners and be contrary to copyright laws.

FCC NOTICE

Multi-Purpose Camera, ME20F-SH Systems.

This device complies with Part 15 of the FCC Rules. Operation is subject to the following two conditions: (1) This device may not cause harmful interference, and (2) this device must accept any interference received, including interference that may cause undesired operation.

Note: This equipment has been tested and found to comply with the limits for a Class A digital device, pursuant to part 15 of the FCC Rules. These limits are designed to provide reasonable protection against harmful interference when the equipment is operated in a commercial environment. This equipment generates, uses, and can radiate radio frequency energy and, if not installed and used in accordance with the instruction manual, may cause harmful interference to radio communications. Operation of this equipment in a residential area is likely to cause harmful interference in which case the user will be required to correct the interference at his own expense.

Do not make any changes or modifications to the equipment unless otherwise specified in the manual. If such changes or modifications should be made, you could be required to stop operation of the equipment.

Only for European Union and EEA (Norway, Iceland and Liechtenstein)



These symbols indicate that this product is not to be disposed of with your household waste, according to the WEEE Directive (2012/19/EU), the Battery Directive (2006/66/EC) and/or national legislation implementing those Directives.

If a chemical symbol is printed beneath the symbol shown above, in accordance with the Battery Directive, this indicates that a heavy metal (Hg = Mercury, Cd = Cadmium, Pb = Lead) is present in this battery or accumulator at a concentration above an applicable threshold specified in the Battery Directive.

This product should be handed over to a designated collection point, e.g., on an authorized one-for-one basis when you buy a new similar product or to an authorized collection site for recycling waste electrical and electronic equipment (EEE) and batteries and accumulators. Improper handling of this type of waste could have a possible impact on the environment and human health due to potentially hazardous substances that are generally associated with EEE. Your cooperation in the correct disposal of this product will contribute to the effective usage of natural resources.

For more information about the recycling of this product, please contact your local city office, waste authority, approved scheme or your household waste disposal service or visit www.canon-europe.com/weee, or www.canon-europe.com/battery.

Important Safety Instructions

In these safety instructions the word “apparatus” refers to the Canon Multi-Purpose Camera ME20F-SH and all its accessories.

1. Read these instructions.
2. Keep these instructions.
3. Heed all warnings.
4. Follow all instructions.
5. Do not use this apparatus near water.
6. Clean only with dry cloth.
7. Do not install near any heat sources such as radiators, heat registers, stoves, or other apparatus (including amplifiers) that produce heat.
8. Refer all servicing to qualified service personnel. Servicing is required when the apparatus has been damaged in any way, liquid has been spilled or objects have fallen into the apparatus, the apparatus has been exposed to rain or moisture, does not operate normally, or has been dropped.

CAN ICES-3 (A)/NMB-3(A)

Warning

This is a class A product. In a domestic environment this product may cause radio interference in which case the user may be required to take adequate measures.

Safety and Handling Precautions

Be sure to observe the following precautions to ensure maximum performance.

- Do not use, store or leave the camera in places subject to high temperatures (60 °C (140 °F) or higher) or the inside of a car parked under direct sunlight.
- Do not use the camera near strong electromagnetic fields such as near powerful magnets and motors, MRI machines or high-voltage power lines. Using the camera in such places may cause anomalies in the video, or audio or video noise to appear.
- Do not use or store the camera in dusty or sandy places. The camera is not waterproof – avoid also water, mud or salt. If any of the above should get into the camera it may damage the camera and/or the lens. Consult a Canon Service Center as soon as possible.
- Be careful to avoid dust and dirt particles accumulating on the lens or entering the camera. When you finish using the camera, make sure to attach the body cap to the lens mount and the lens cap and dust cap to the lens.
- Have the cooling fan replaced after the [Total] hour meter displayed in the [Other Functions]  [Reset Hour Meter] submenu reaches approximately 30,000 hours. Consult a Canon Service Center to have it replaced.
- Do not point the camera toward an intense light source, such as the sun on a sunny day or an intense artificial light source. Doing so may damage the image sensor or the camera's internal components. Be careful especially when using a tripod. When you are not using the camera, make sure to attach the lens cap to the lens.
- Be careful of heat generated by lighting equipment.
- Do not disassemble the camera. If the camera does not function properly, consult qualified service personnel.
- Do not touch the lens contacts on the lens mount. Dirty contacts may cause a poor contact between the camera and the lens resulting in incorrect operation of the camera. After removing the lens, make sure to attach the body cap to the lens mount and the lens cap and dust cap to the lens.
- Make sure to turn off the camera before disconnecting a power cable.
- Handle the camera with care. Do not subject the camera to shocks or vibration as this may cause damage.
- **Long-term storage:** If you do not intend to use the camera for a long time, store it in a place free of dust, in low humidity, and at temperatures not higher than 30 °C (86 °F).

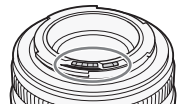

Trademark Acknowledgements

- HDMI, the HDMI logo and High-Definition Multimedia Interface are trademarks or registered trademarks of HDMI Licensing LLC in the United States and other countries.
- Other names and products not mentioned above may be trademarks or registered trademarks of their respective companies.

Highlights of the ME20F-SH

The Canon ME20F-SH Multi-Purpose Camera boasts numerous features that allow it to excel in a variety of situations. The following highlights some of the ways that this camera can meet your needs.

HD Video

High-sensitivity 35mm full-frame CMOS sensor and DIGIC DV 4 image processor

The camera is equipped with a high-sensitivity 35mm full-frame CMOS sensor that features improved noise reduction circuitry and pixels measuring a relatively large 19 μm^* square in size. Combined with the DIGIC DV 4 image processor, the camera is capable of shooting video in dim environments (minimum subject illumination: 0.0005 lux**) with little video noise.

* Micrometer. Also referred to as a micron, it is one millionth of a meter.

** Under the following conditions: color, no light accumulation, f/1.2, 30P, 50 IRE, maximum gain 75 dB (ISO equivalent of 4 million).

Interchangeable lenses

Enjoy the versatility of using interchangeable lenses to achieve the look you want. The camera is equipped with an EF lens mount, which allows you to use a variety of high-quality lenses from the EF Lens and EF-S Lens series. For more details on compatible lenses, visit your local Canon Web site.

HD video output and versatile video configuration

The camera will output HD video from the 3G/HD-SDI terminals and HDMI OUT terminal to be recorded with an external video recorder. Before you shoot, you can select the system frequency (50.00 Hz or 59.94 Hz), resolution and frame rate. These settings collectively comprise the video configuration (☐ 31) and you can select a configuration that best suits your needs.

Adaptability to a wide range of lighting conditions

Although the camera excels in low-light environments, thanks to the aforementioned technology behind the CMOS sensor, it is well-equipped to shoot in other lighting conditions. When the shooting environment is too bright, you can employ the ND filter (☐ 39), which is

available in two density levels, to help manage the brightness. Oppositely, you can shoot in dark environments by using infrared mode (☐ 46).

Operability and Customization

Enhanced automatic functions

The camera is equipped with various automatic functions to help achieve the picture you desire. These include the following: automatic exposure, which is controlled through the linked settings of the aperture, gain, shutter speed and ND filter; push auto iris (☐ 34) to temporarily adjust the aperture automatically; automatic white balance (☐ 40) to let the camera continuously adjust the optimal white balance setting; and one-shot AF (☐ 43) to have the camera focus automatically one time after you press the button.

Remote operation

You can attach the optional RC-V100 Remote Controller (☐ 47) to the camera to control it from a distance. The remote controller allows you to control many of the camera's settings.

Assignable buttons

You can assign often-used functions to assignable buttons (☐ 48) so that you can call up those functions with the press of a single button.

Custom picture settings and Canon Log gamma

With custom picture settings (☐ 50), you can enjoy unparalleled image control to deliver the look you want by adjusting parameters, such as gamma and sharpness. You can even select the Canon Log and Wide DR gamma settings found on Canon Cinema EOS cameras.

Table of contents

Safety and Handling Precautions 4

1. Introduction 7

Introduction 7

Supplied Accessories 7

Conventions Used in this Manual 7

Names of Parts 10

Example Configuration 15

2. Preparations 16

Preparing the Power Supply 16

Using the DC IN 1 Terminal 16

Using the DC IN 2 Terminal 17

Turning the Camera On and Off 17

Connecting to an External Monitor 18

Connection Diagram 18

Date and Time Settings 19

Using the Menu 20

Selecting an Option from the Menu 20

Preparing the Camera 22

Adjusting the Black Balance 22

Preparing the Lens 22

Overview of Connecting to External

Devices 25

Installing the Camera 26

3. Shooting Video and Shooting Functions 27

Shooting Video 27

Onscreen Displays 28

Video Configuration: System Frequency,

Frame Rate and Resolution 31

Selecting the System Frequency 31

Selecting the Frame Rate 31

Selecting the Resolution 31

Adjusting Main Camera Functions with the Joystick 32

Setting the Camera Mode: Auto and

Manual Modes 33

Adjusting the Aperture 34

Manual Aperture 34

Momentary Automatic Aperture - Push

Auto Iris 34

Exposure Compensation - AE Shift 35

Light Metering Mode 35

Gain 37

Manual Adjustment 37

Auto Gain Control (AGC) Limit 37

Shutter Speed 38

ND Filter 39

White Balance 40

Auto White Balance (AWB) 40

Custom White Balance 41

Color Temperature/Preset White Balance 41

Adjusting the Focus 43

Manual Focus 43

One-Shot AF 43

Infrared Mode 46

Using the Optional RC-V100 Remote Controller 47

4. Customization 48

Assignable Buttons 48

Changing the Assigned Function 48

Using an Assignable Button 49

Custom Picture Settings 50

Selecting Custom Picture Files 50

Editing a Custom Picture File's Settings 51

Available Custom Picture Settings 51

Customizing Onscreen Displays 54

5. External Connections 55

Connecting to an External Recorder 55

Outputting a Recording Command to an External Recorder 55

Synchronizing with an External Device 57

Audio Input and Output 58

Audio Input 58

Audio Output 58

6. Additional Information 59

Menu Options 59

Onscreen Warning Displays and Messages 65

Maintenance/Others 66

Optional Accessories 67

Specifications 68

Appendix 70

Physical Measurements 70

Index 72

1 Introduction

Introduction

Thank you for purchasing the Canon ME20F-SH. Please read this manual carefully before you use the camera and retain it for future reference.

Supplied Accessories

The following accessories are supplied with the camera.



Body Cap*

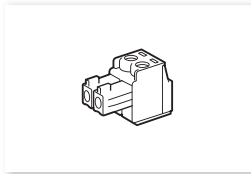

Power connector

* Comes pre-attached to the camera.

Conventions Used in this Manual

- **!** IMPORTANT: Precautions related to the camera's operation.
- **i** NOTES: Additional topics that complement the basic operating procedures.
- **📖**: Reference page number.
- The following terms are used in this manual.

"Screen" refers to the screen of an external monitor connected to the camera.

"Shooting screen" refers to the screen in which the shooting image and onscreen displays appear.

Note that onscreen displays will appear only with the video signal output from camera's 3G/HD-SDI 1 / MONITOR terminal or HDMI OUT terminal, not with the video signal output from the 3G/HD-SDI 2 terminal.

- Some screenshots have been altered to make them easier to read.
- Illustrations in the manual show the Canon ME20F-SH camera with a Canon EF 70-200mm f/2.8L IS II USM lens attached. For simplicity's sake, the lens's tripod mount is not displayed in the illustrations.

The  arrow is used to abbreviate menu selections. For a detailed explanation on how to use the menu, refer to *Using the Menu* (📖 20). For a concise summary of all available menu options and settings, refer to *Menu Options* (📖 59).

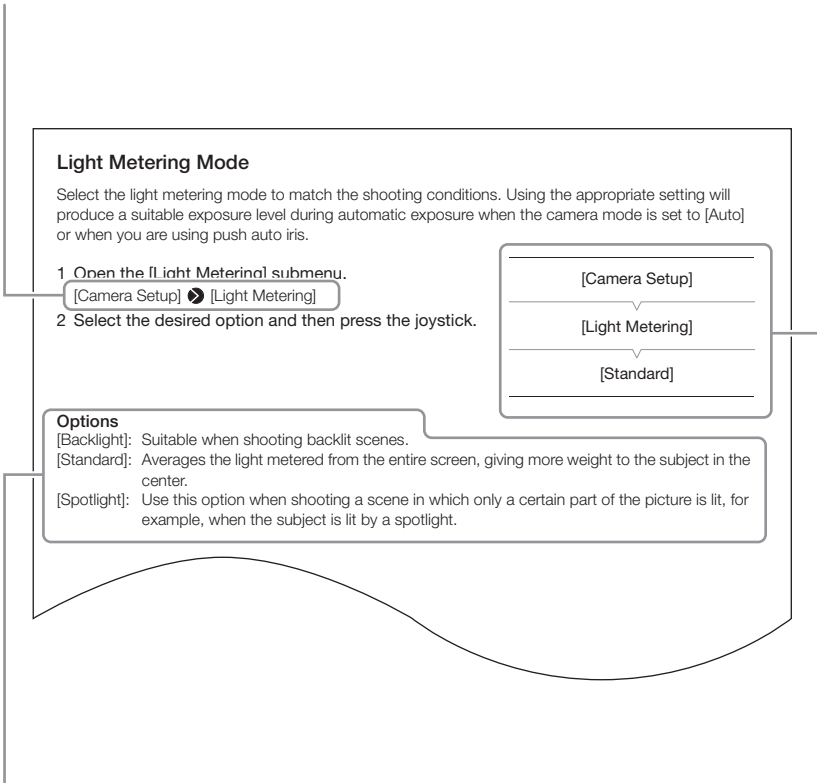

Light Metering Mode

Select the light metering mode to match the shooting conditions. Using the appropriate setting will produce a suitable exposure level during automatic exposure when the camera mode is set to [Auto] or when you are using push auto iris.

1 Open the [Light Metering] submenu.
[Camera Setup]  [Light Metering]

2 Select the desired option and then press the joystick.

Options

- [Backlight]: Suitable when shooting backlit scenes.
- [Standard]: Averages the light metered from the entire screen, giving more weight to the subject in the center.
- [Spotlight]: Use this option when shooting a scene in which only a certain part of the picture is lit, for example, when the subject is lit by a spotlight.

The diagram illustrates the menu structure for Light Metering Mode. It shows a sequence of menu selections: [Camera Setup] followed by [Light Metering], which then leads to a submenu with [Standard] as the selected option. A separate box lists the options: [Backlight], [Standard], and [Spotlight], each with a brief description of when to use it.

When a procedure requires selecting an option, the available options are listed within or after the procedure. Brackets [] are used to refer to menu options as they are displayed on screen.

When a function requires the use of the menu, the quick reference shows the submenus and, when applicable, the default setting for the menu item. The example illustration indicates that you can find the function by selecting the [Other Functions] menu and then the [Frame Rate] menu item.

Before Using the Camera

Note the following before using the camera.

Privacy and Publicity Rights

When using the camera (for video or audio recording), it is the full responsibility of the user to avoid any violation of privacy or publicity rights. For example, obtain consent to install the camera in advance if specific buildings or rooms are to be monitored. Canon shall have no liability whatsoever in this regard.

Legal Notice

In some cases camera monitoring may be prohibited by law or regulation, the details of which differ by country or region. Before using the camera, check the laws and regulations of the country or region where the camera is to be used.

Names of Parts

Back view

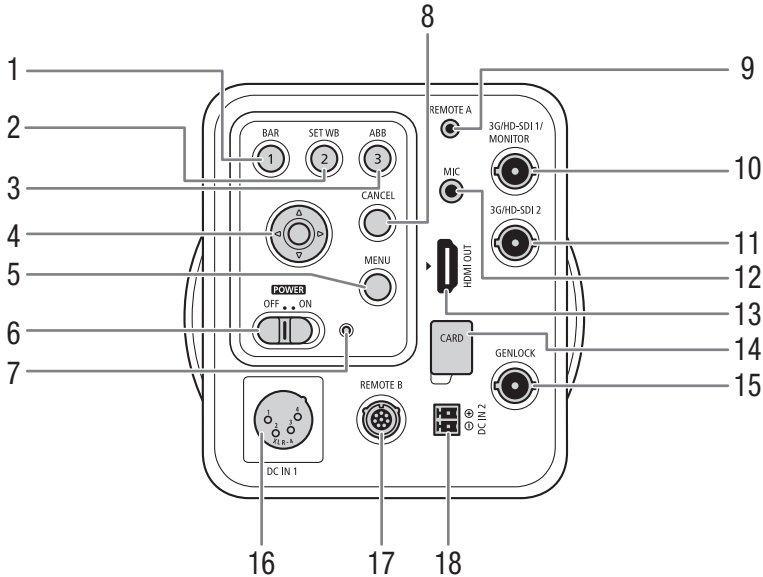

10

- | | |
|--|---|
| <p>1 BAR (color bars) button (📖 28)/
Assignable button 1 (📖 48)</p> <p>2 SET WB (custom white balance) button
(📖 41)/Assignable button 2 (📖 48)</p> <p>3 ABB (automatic black balance) button
(📖 22)/Assignable button 3 (📖 48)</p> <p>4 Joystick (📖 20)</p> <p>5 MENU button (📖 20)</p> <p>6 POWER switch (📖 17)</p> <p>7 POWER indicator (📖 17)</p> <p>8 CANCEL button (📖 20)</p> <p>9 REMOTE A (remote control) terminal
(📖 47)
For connecting to the optional
RC-V100 Remote Controller's
REMOTE A terminal.</p> | <p>10 3G/HD-SDI 1 / MONITOR terminal
(📖 18, 55)</p> <p>11 3G/HD-SDI 2 terminal (📖 18, 55)</p> <p>12 MIC (microphone) terminal (📖 58)</p> <p>13 HDMI OUT terminal (📖 18, 55)</p> <p>14 Memory card cover
Memory card usage is reserved for
maintenance only.</p> <p>15 GENLOCK terminal (📖 57)</p> <p>16 DC IN 1 terminal (📖 16)</p> <p>17 REMOTE B (remote control) terminal
(📖 47)
For connecting to the optional
RC-V100 Remote Controller's
REMOTE B terminal.</p> <p>18 DC IN 2 terminal (📖 17)</p> |
|--|---|

Front view

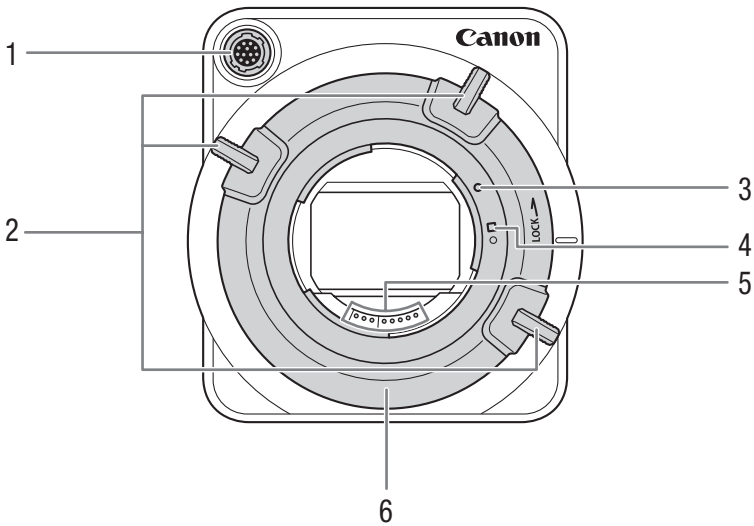

- | | |
|---|--|
| <p>1 LENS terminal
Currently, not yet available for use.
Lens operational control will be made available in a future firmware update.</p> <p>2 Lens mount handle (📖 22)</p> | <p>3 EF lens mount index (📖 22)</p> <p>4 EF-S lens mount index (📖 22)</p> <p>5 EF lens contacts (📖 22)</p> <p>6 EF lens mount (📖 22)</p> |
|---|--|

Top view

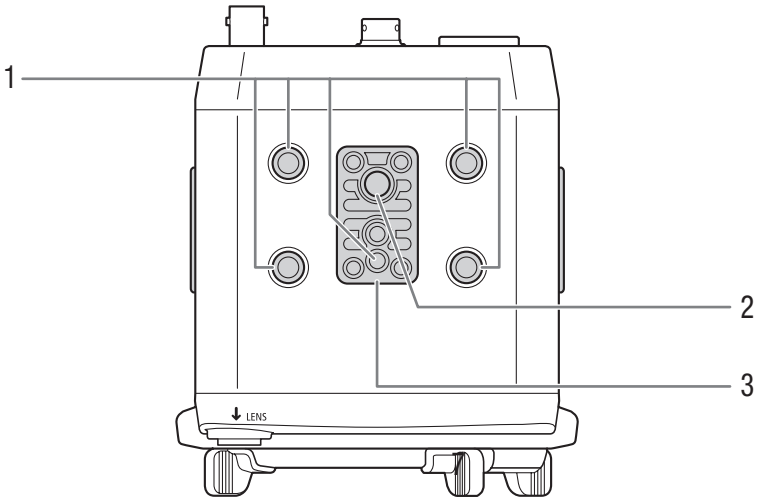

12

- 1 Socket for 0.64 cm (1/4 in.) screws
- 2 Socket for 0.95 cm (3/8 in.) screws (📖 26)

- 3 TB-1 Tripod Base for tripods with 0.95 cm (3/8 in.) screws (📖 26)

Bottom view

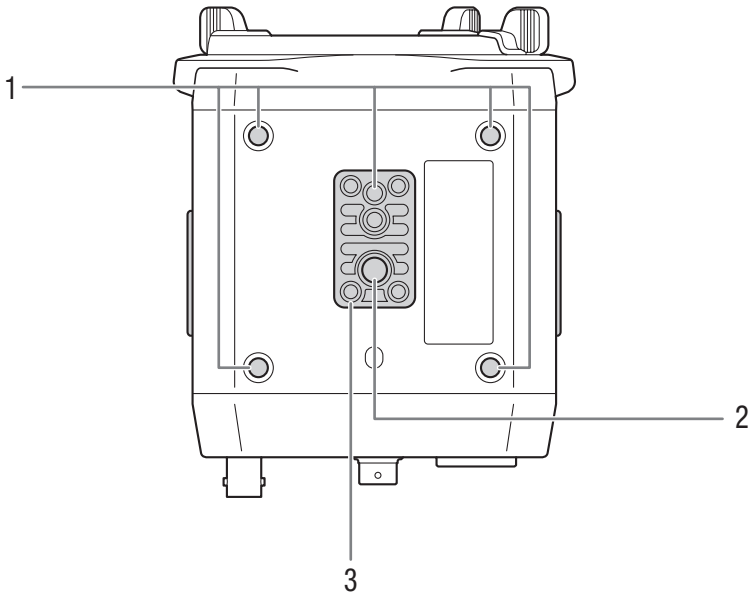

- 1 Socket for 0.64 cm (1/4 in.) screws
- 2 Socket for 0.95 cm (3/8 in.) screws (📖 26)
- 3 TB-1 Tripod Base for tripods with 0.95 cm (3/8 in.) screws (📖 26)

Right side view

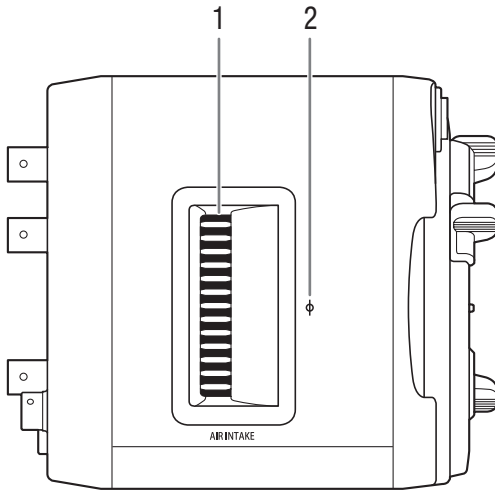

1 Air intake vent (62)

2 Focal plane mark

Left side view

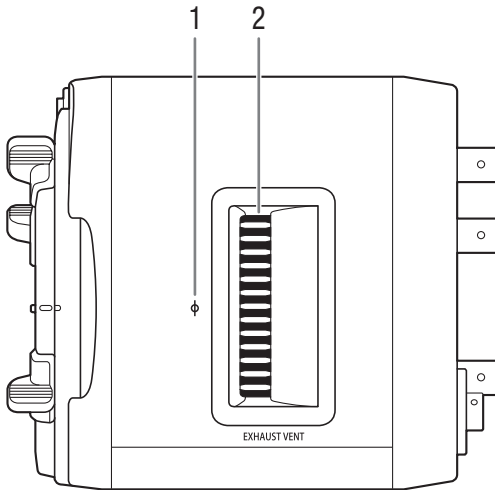

1 Focal plane mark

2 Exhaust ventilation outlet (62)

Example Configuration

The following example configuration illustrates how to connect the camera to external devices such as a monitor (18) or video recorder (55).

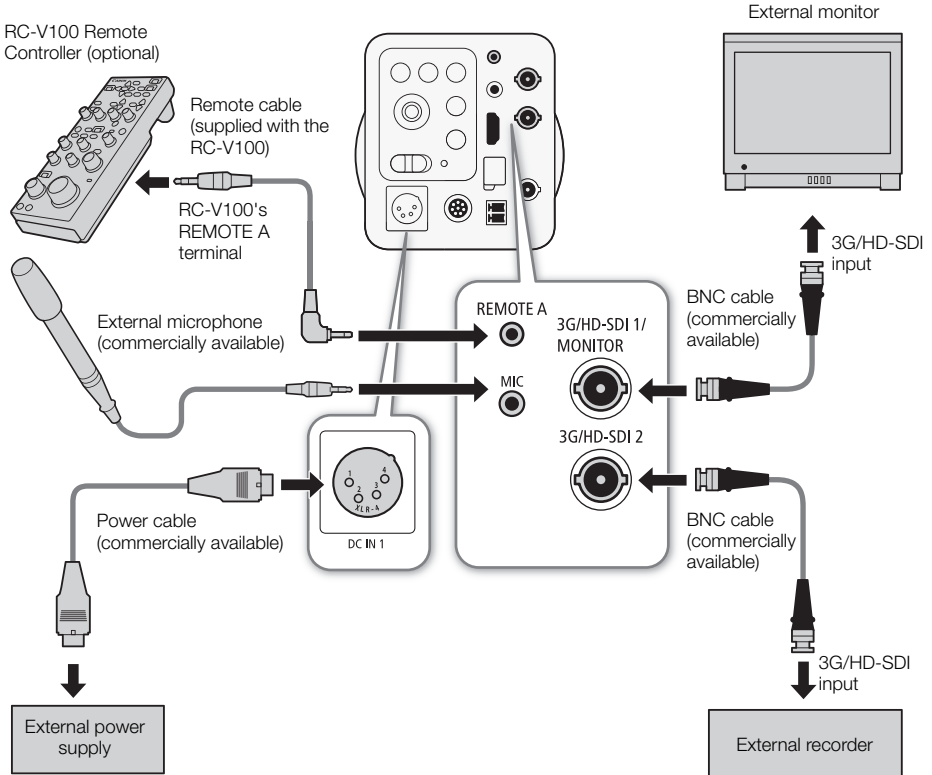

i NOTES

- If you plan on connecting the optional RC-V100 Remote Controller to the camera using the optional RR-10 or RR-100 8-pin Remote Cable, check the serial number of the RC-V100. If the serial number starts with "01 xxxx" (where xxxx represents other digits), you will need to update the remote controller's firmware. Canon will perform this feature upgrade, and requires that RC-V100 Remote Controller be sent to an accredited Canon service center. Shipping and handling charges may apply. Contact a Canon Customer Support Center for details.
- When connecting the optional RC-V100 Remote Controller to the camera, make sure that the remote controller's terminal selection switch is set to match the terminal to be used on the camera.

2 Preparations

Preparing the Power Supply

You can power the camera using a commercially available external power supply connected to the DC IN 1 terminal (via a commercially available power cable with a female 4-pin XLR connector) or the DC IN 2 terminal (via a commercially available power cable capable of connecting to the supplied power connector). The external power supply and power cable **must conform to the following specifications** and be certified to meet safety standards set by UL, CSA or similar organization.

External power supply (commercially available)

Power supply (output): 11 to 17 V DC
Current (output): 3 A or higher

Power cable (commercially available)

Power cable rating: 5 A (maximum) / 30 V DC (rated)

Using the DC IN 1 Terminal

Refer to the following terminal configuration when selecting a power cable.

DC IN 1 terminal configuration

Pin	Signal
1	Ground
2	Unused
3	Unused
4	11 to 17 V DC

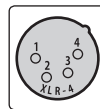

DC IN 1

Terminal type: 4-pin XLR (male)

- 1 Set the **POWER** switch to OFF (①).
- 2 Connect the 4-pin XLR connector to the DC IN 1 terminal (②).

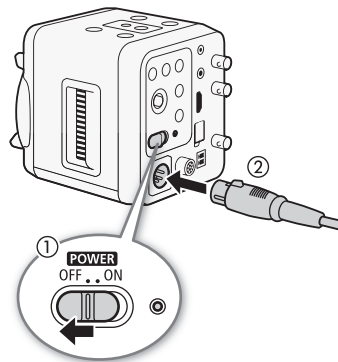

Using the DC IN 2 Terminal

DC IN 2 terminal configuration

Polarity	Signal
+	11 to 17 V DC
-	Ground

- 1 Connect the power cable to the supplied power connector as shown in the illustration (①).
 - Make sure to connect the wires to match the polarity indicators on the DC IN 2 terminal.
- 2 Set the **POWER** switch to OFF (②).
- 3 Insert the power connector into the DC IN 2 terminal (③).

! IMPORTANT

- Make sure to use an external power supply that meets the standards of the country/region where it is used. Furthermore, make sure the external power supply is a double-insulated device and is insulated for commercial power use.
- The power supply should also comply with IEC/UL60950-1 (SEVL/LPS) standards.

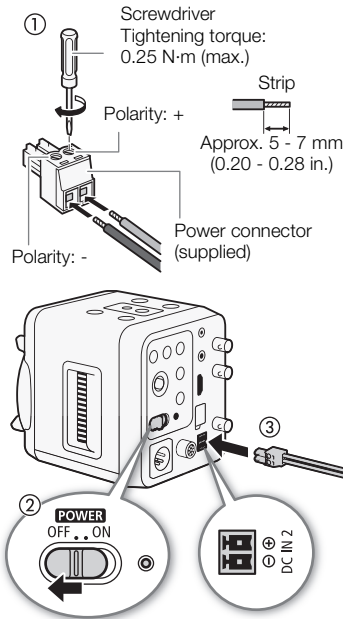

Turning the Camera On and Off

Set the **POWER** switch to ON to turn on the camera and set it to OFF to turn off the camera.

- The **POWER** indicator will illuminate in green while the camera is on. However, you can use the [Other Functions] ➤ [Power LED] setting to turn the indicator off.

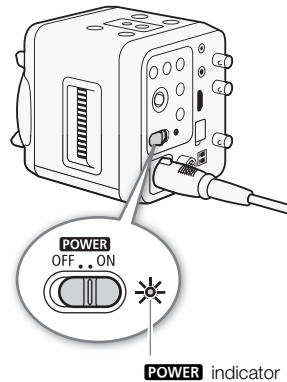

POWER indicator

Connecting to an External Monitor

Connect the camera to an external monitor using the 3G/HD-SDI 1 / MONITOR terminal, 3G/HD-SDI 2 terminal or HDMI OUT terminal. Use the terminal on the camera that matches the one you wish to use on the monitor.

Video and audio will be output as a digital signal from the aforementioned terminals.

Connection Diagram

Refer to the following connection diagram. When connecting the camera using the 3G/HD-SDI 1 / MONITOR terminal or 3G/HD-SDI 2 terminal, use a commercially available BNC cable; when using the HDMI OUT terminal, use a commercially available HDMI cable.

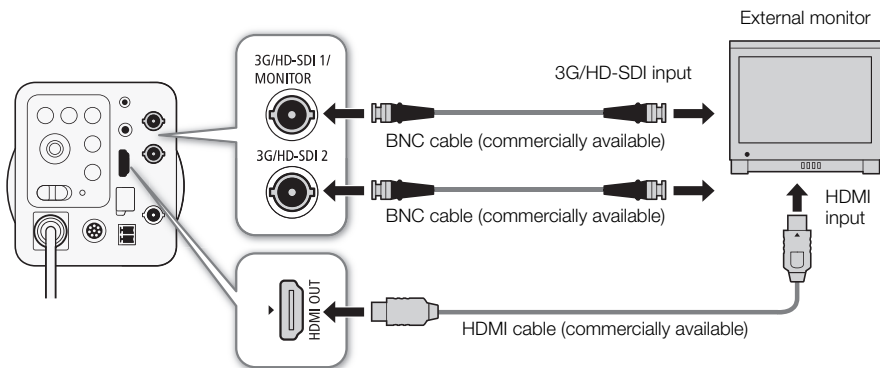

NOTES

- If video output from the camera does not appear on the screen when using a 3G-SDI connection, perform the following.
 - Check that the external monitor is compatible with the 3G-SDI standard.
 - Check that the [Other Functions] ➤ [Frame Rate] setting and [Audio/Video Setup] ➤ [3G-SDI Mapping] settings are set correctly.
- For external monitors that support only 480P or 576P input, connect the camera using a commercially available HDMI cable.
- When the output signal is 480P or 576P, onscreen displays will not be superimposed on the video signal.
- Onscreen displays will not be superimposed on the video signal output from the 3G/HD-SDI 2 terminal. To output onscreen displays, use the 3G/SHD-SDI 1 / MONITOR terminal or HDMI OUT terminal.

Date and Time Settings

You will need to set the date and time of the camera before you can start using it. When the camera's clock is not set, the [Date/Time] screen will appear automatically with the first field selected (month or day, depending on the country/region of purchase).

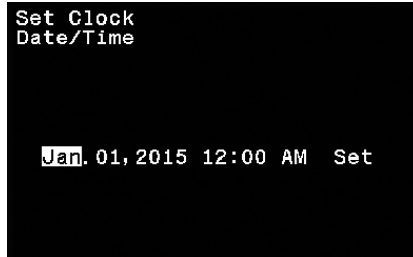

- 1 Push the joystick up/down to change the month/day then push it right to move to the next field.
 - To move to the next field you can also press the joystick itself.
- 2 Change the rest of the fields in the same way.
- 3 Select [Set] and then press the joystick to start the clock and close the screen.

NOTES

- While a recording command is being output to an external recorder to start recording (📖 55), you cannot change the date/time or time zone.
- With the following settings, you can change the time zone, date and time also after the initial setup. You can also change the date format and clock format (12 or 24 hours).
 - [Other Functions] ➤ [Time Zone]
 - [Other Functions] ➤ [Set Clock] ➤ [Date/Time] and [Date Format]
- When the built-in rechargeable lithium battery is exhausted, the date and time setting may be lost. In such case, recharge the built-in lithium battery (📖 65) and set the time zone, date and time again. Similarly, if the camera's settings have been reset, you will need to perform the setup again.
- The time indicated on the screen is approximate.
- You can display the date/time on the screen with the [Other Functions] ➤ [Custom Display] ➤ [Date/Time] setting.

Using the Menu

Many of the camera's functions can be adjusted from the menu that opens after pressing the MENU button. You can also assign frequently used functions to the assignable buttons (📖 48) so that you can quickly access those functions. For details about the available menu options and settings, refer to *Menu Options* (📖 59).

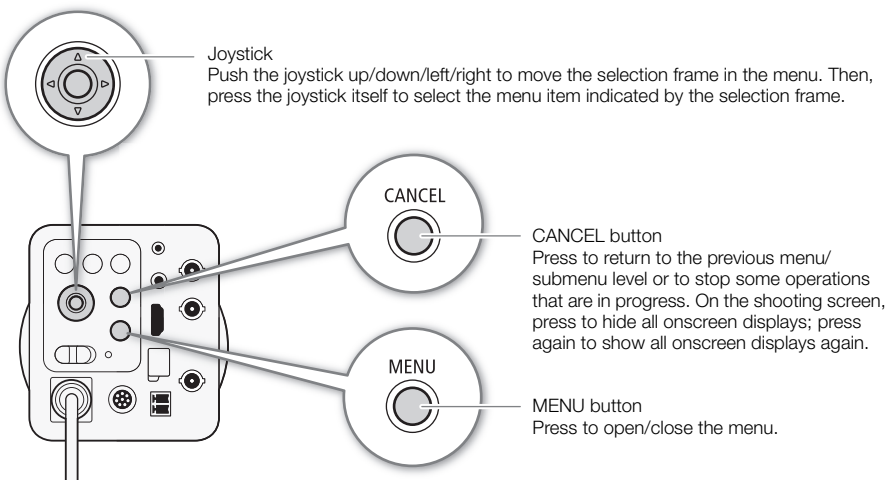

Selecting an Option from the Menu

The following is a step-by-step explanation of how to select an option from the menu. In the procedures throughout the rest of this manual, opening and closing the menu is assumed and not included in the procedure.

1 Press the MENU button.

- The menu opens with the orange selection frame indicating the menu item that was selected the previous time the menu was closed (unless the camera was turned off).

2 Push the joystick up/down to select the desired submenu.

3 Push the joystick right or press the joystick.

- The selection frame will appear on a menu item in the submenu.
- Press the CANCEL button or push the joystick left to return to the previous submenu. For some submenus, you can alternatively select [\leftarrow].

4 Push the joystick up/down to select the desired menu item.

- If a submenu contains many items, push the joystick up/down to scroll up/down and see other menu items.
- A [\rightarrow] next to a menu item indicates another submenu. Repeat steps 3 and 4.

5 Push the joystick right or press the joystick.

- The selection frame will appear on a setting option.
- Press the CANCEL button to return to the previous submenu.

6 Push the joystick up/down to select the desired setting option and then press the joystick.

- Depending on the menu item, additional selections may be necessary.

7 Press the MENU button to close the menu.

- Alternatively, if the top-level of the menu (with [Camera Setup], [Custom Picture], etc.) is displayed, you can select [CLOSE].

i NOTES

- Unavailable items may appear grayed out.
- Pressing the MENU button at any time closes the menu (except for the [Other Functions] ➤ [Camera Name] setting screen).
- When an optional RC-V100 Remote Controller is connected to the camera, you can use the remote controller's up/down/left/right/SET buttons in the same way as the camera's joystick. Pressing the SET button is equivalent to pressing the joystick on the camera. Similarly, pressing the MENU or CANCEL button is equivalent to pressing the MENU or CANCEL button on the camera, respectively.

Preparing the Camera

This section outlines the basic preparations for the camera.

Adjusting the Black Balance

The first time you use the camera or if there is a noticeable change in the blacks of the video signal (such as when ambient temperature changes considerably), you can have the camera adjust the black balance automatically.

1 Set the **POWER** switch to OFF and attach the body cap to the lens mount.

- If a lens was attached, remove the lens and replace the body cap.

2 Set the **POWER** switch to ON.

3 Press the ABB button.

- Alternatively, you can use the [Camera Setup] ► [ABB] setting.

4 Select [OK] and then press the joystick.

- The automatic black balance procedure will start. It will take approximately 40 seconds when the frame rate is set to 23.98P.

5 When the message [Process completed successfully.] appears, press the joystick.

- If the sensor is not completely shielded from light, [ABB error] will appear on the screen. Press the joystick and repeat the procedure from the beginning.

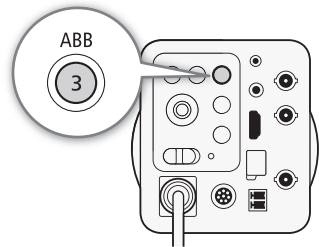

NOTES

- Adjusting the black balance is necessary in the following cases:
 - After a long period of not using the camera.
 - After sudden or extreme changes in ambient temperature.
 - After resetting the camera's settings using either option in the [Other Functions] ► [Reset] setting.
- During the adjustment of the black balance, you may notice some irregular displays appear on the screen. This is not a malfunction.

Preparing the Lens

As much as possible, attach and remove the lens quickly and in a clean environment free of dust. Refer also to the instruction manual of the lens used.

IMPORTANT

- When attaching/removing a lens, avoid direct sunlight or strong light sources. Also, be careful not to drop the camera or lens.

i NOTES

- After removing a lens or when a lens is not attached to the camera:
 - Do not touch the lens's surfaces, the lens mount or any components inside the lens mount area.
 - Place the body cap back on the lens mount and the dust caps back on the lens. Clean any dust or dirt from the body cap and dust caps before using them.

Attaching an EF Lens

- 1 Set the **POWER** switch to OFF.
- 2 Turn the lens mount handle clockwise until it stops (2).
- 3 Remove the body cap from the camera and any dust caps from the lens (3).
- 4 Align the lens and mount making sure that the index marks are aligned (4).
 - EF lenses: Align the red mark on the lens with the red EF Lens mount index mark on the camera.
 - EF-S lenses: Align the white mark on the lens with the white EF-S Lens mount index mark on the camera.
- 5 After the lens is attached to the camera, without turning the lens, turn the lens mount handle counter-clockwise until it is tightened firmly (5).

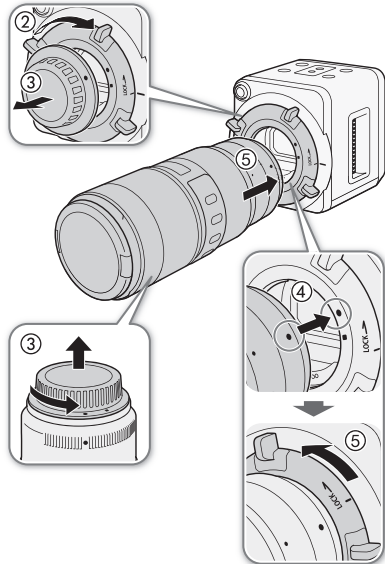

Removing an EF Lens

- 1 Set the **POWER** switch to OFF.
- 2 While holding the bottom of the lens, turn the lens mount handle clockwise until it stops (2).
 - Make sure not to drop the lens when removing it.
- 3 Place the body cap back on the lens mount and the dust caps back on the lens (3).

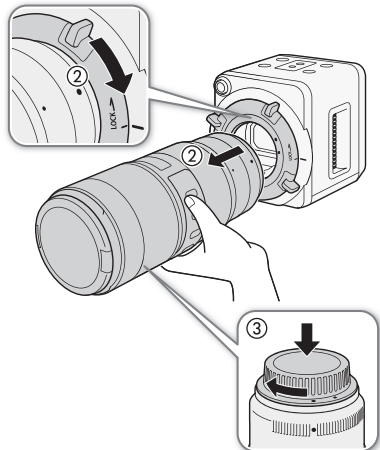

i NOTES

- **About using an EF-S lens:** This camera's sensor is larger than the sensor size for which EF-S lenses are designed (APS-C). When using EF-S lenses with this camera, you may notice peripheral illumination fall-off or vignetting. To prevent this, you can use the [Camera Setup] ➤ [EF-S Lens] setting to change the sensor area that is used for producing the image. This setting digitally enlarges the image by a factor of approx. 1.48 so the image quality will deteriorate.
- Depending on the lens's characteristics, the corners of the picture may seem darker due to light fall-off or illumination drop. You can use the [Camera Setup] ➤ [Periph.Illum.Corr.] setting to have the camera compensate if it has the correction data available for the lens.
- If you are using a compatible lens, you can use the [Camera Setup] ➤ [Zoom-Iris Correct.] setting to have the camera adjust the aperture while zooming.

Peripheral Illumination Correction

Depending on the characteristics of the lens used, the image around the corners of the picture may seem darker due to light fall-off or peripheral illumination drop. If the camera has correction data available for the EF lens used, it can apply this correction data to compensate as necessary.

1 Attach the lens you want to use.

2 Open the peripheral illumination correction screen.

[Camera Setup] ➤ [Periph.Illum.Corr.]

- If correction data is available, the lens model name will appear on the screen.
- If correction data is not available, [Periph.Illum.Corr.] will appear grayed out. Visit your local Canon Web site and check if there is correction data available for the lens you are using. If so, download the necessary update package and upgrade the camera's firmware following the instructions supplied therein.

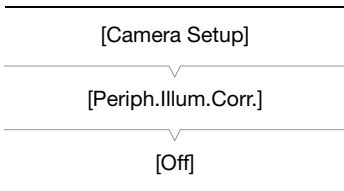

3 Select [On] and then press the joystick.

- As long as [Camera Setup] ➤ [Periph.Illum.Corr.] is set to [On], the camera will automatically apply the appropriate correction data.

i NOTES

- No correction will be applied in the following cases:
 - When correction data is not available for the attached lens.
 - When using non-Canon lenses. Even if the [Periph.Illum.Corr.] setting is available (not grayed out), setting it to [Off] is recommended.
- **About lens correction data:**
 - The camera contains a register of correction data for most compatible lenses that were available at the time the camera went on sale. Correction data for future lenses will be made available as part of the regular updates released for the camera's firmware. For more details, visit your local Canon Web site.
 - Depending on the shooting conditions, noise may appear in the periphery of the image as a result of the correction.
 - The level of correction will be lower for lenses that cannot provide distance information.
 - The level of correction will be lower the higher the gain setting used.

Overview of Connecting to External Devices

There are many ways in which you can configure the camera by connecting external devices. You can connect an external monitor, external recorder, optional RC-V100 Remote Controller or external microphone, as necessary. Refer to the following pages for more details.

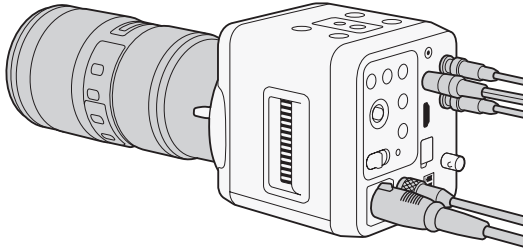

- For an external monitor, refer to *Connecting to an External Monitor* (18).
- For an external recorder, refer to *Connecting to an External Recorder* (55).
- For an optional RC-V100 Remote Controller, refer to *Using the Optional RC-V100 Remote Controller* (47).
- For an external microphone, refer to *Audio Input and Output* (58).
- For synchronizing the camera with an external device, refer to *Synchronizing with an External Device* (57).

Installing the Camera

Depending on where you install the camera, you may want to use a commercially available tripod, pan/tilt head, housing unit or other accessory. The camera is shipped with two TB-1 Tripod Bases for tripods and accessories with 0.95 cm (3/8 in.) screws. In addition, the camera body itself is equipped with sockets for 0.64 cm (1/4 in.) screws.

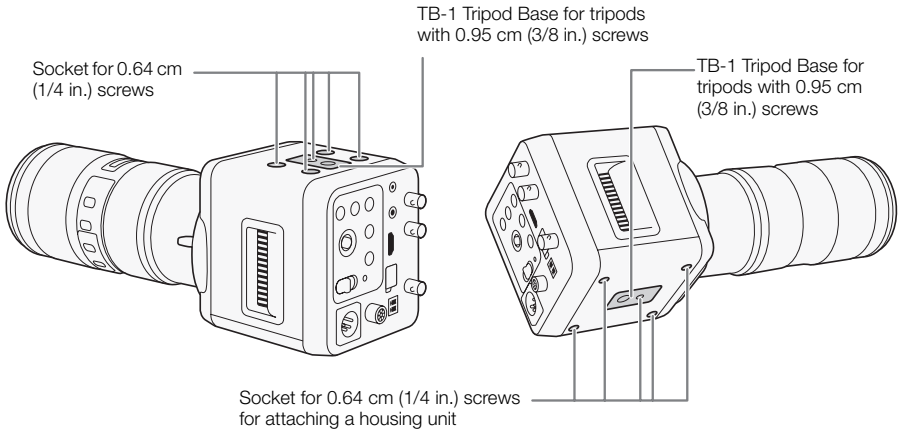

! IMPORTANT

- You can mount the camera on a tripod or similar accessory but do not use accessories with mounting screws longer than 5.5 mm (0.2 in.).

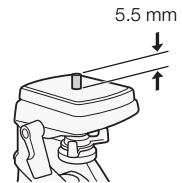

3

Shooting Video and Shooting Functions

Shooting Video

This section explains shooting-related functions. For details on audio output, refer to *Audio Input and Output* (📖 58).

Before shooting video for the first time, connect an external monitor and microphone to check that video and audio are being output correctly. Should the camera fail to operate correctly, consult a Canon Service Center.

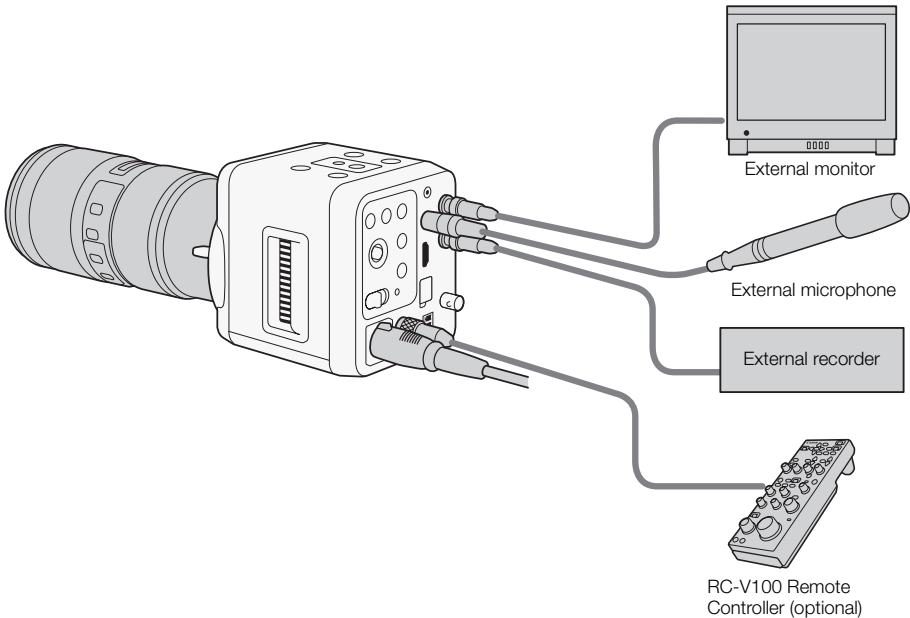

- 1 Set the **POWER** switch to ON.
 - The camera turns on and the shooting screen appears.
- 2 Adjust the video configuration (📖 31) and other shooting-related functions, as necessary.
 - For details about shooting-related functions, refer to the relevant sections in this chapter.
- 3 Shoot video.
 - For details on recording to an external recorder, refer to *Connecting to an External Recorder* (📖 55).

! IMPORTANT

- Be careful not to obstruct in any way the fan's air vents.

i NOTES

- You can have the camera output color bars using the following controls or settings. Furthermore, you can select the type of color bars using the [Camera Setup] ➤ [Color Bars] ➤ [Type] setting.
 - Press the BAR button.
 - Use the [Camera Setup] ➤ [Color Bars] ➤ [Activate] setting.
 - When an optional RC-V100 Remote Controller is connected to the camera, you can press the remote controller's BARS button.
- You can use the [Audio/Video Setup] ➤ [1kHz Tone] setting to output a 1-kHz audio reference signal with the color bars.
- When you use a commercially available lens adapter and the image on the screen is inverted, you can use the [Other Functions] ➤ [Scan Reverse] setting to return the image to the correct orientation.
- You can set the speed of the cooling fan with the [Other Functions] ➤ [Fan Speed] setting.
- While the fan is running, the exhaust vent will emit warm air.
- If [Fan] appears in red on the screen, the cooling fan may not be working properly. Consult a Canon Service Center.

Onscreen Displays

Refer to this section for an explanation of the various screen displays that appear on the shooting screen when an external monitor is connected to the camera's 3G/HD-SDI 1 / MONITOR terminal or HDMI OUT terminal. You can use the custom display function (☰ 54) to turn off most individual onscreen displays if they are not required. The "Custom Display" column indicates the setting in [Other Functions] ➤ [Custom Display] used to turn the display on/off. If "-" appears in that column for a display, it cannot be turned off.

The screen display layout will differ depending on the camera mode.

Camera mode set to [Auto]

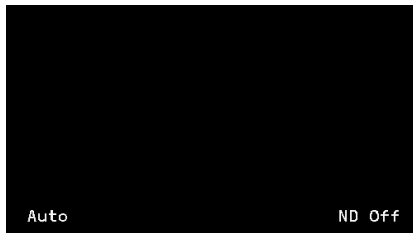

Camera mode set to [Manual]

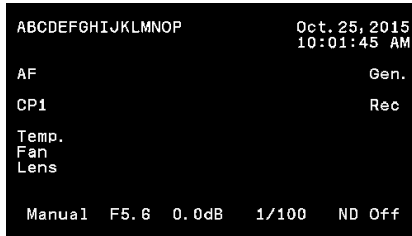

29

Left side and center of the screen

Display	Description	Custom Display	
ABCDEFGHIJKLMNOP	Camera name.	[Camera Name]	63
AF	Autofocus operation (one-shot AF).	–	43
CP1 to CP6, EOS, WDR, C.Log	Currently selected custom picture file.	[Custom Picture]	50
Temp. (in red)	Temperature warning.	[Temperature Warning]	65
Fan (in red)	Fan warning.	–	65
Lens (in red)	Lens error warning.	[Lens Error]	65
AWB, WB-A, WB-B, Dylt, Tung 00000K, ±0	White balance.	[White Balance]	40
Auto, Manual	Camera mode.	[Camera Mode]	33
F0.0	Aperture value.	[Iris]	34
00.0dB	Gain value.	[Gain]	37

Right side of the screen

Display	Description	Custom Display	
Date/time	Date and time.	[Date/Time]	–
Gen.	Genlock.	–	57
Rec	Recording command being output to an external recorder.	–	55
1/0000	Shutter speed.	[Shutter Speed]	38
ND Off, ND 1/8, ND 1/64	ND filter setting.	[ND Filter/Infrared]	39
IR	Infrared mode.	[ND Filter/Infrared]	46

 NOTES

- On the shooting screen, press the CANCEL button to hide all onscreen displays; press the button again to show all onscreen displays again.
- For external monitors that support only 480P or 576P input, connect the camera using a commercially available HDMI cable.
- When the output signal is 480P or 576P, onscreen displays will not be superimposed on the video signal.
- Onscreen displays will not be superimposed on the video signal output from the 3G/HD-SDI 2 terminal. To output onscreen displays, use the 3G/HD-SDI 1 / MONITOR terminal or HDMI OUT terminal.

Video Configuration: System Frequency, Frame Rate and Resolution

You can set the video configuration by selecting the resolution (frame size) and frame rate. Available frame rate options will depend on the selected system frequency. See the table following the procedures for a summary.

Selecting the System Frequency

Perform the following procedure to change the system frequency to either 59.94 Hz or 50.00 Hz.

- 1 Open the [System Frequency] submenu.
[Other Functions] ➤ [System Frequency]
- 2 Select the desired option and then press the joystick.
 - If you changed the system frequency from the current setting, the camera will restart in the selected system frequency.

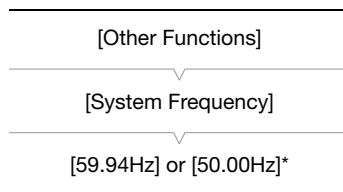

* Depending on the country/region of purchase.

Selecting the Frame Rate

- 1 Open the [Frame Rate] submenu.
[Other Functions] ➤ [Frame Rate]
- 2 Select the desired option and then press the joystick.
 - When connecting the camera using a 3G-SDI connection, select [59.94P] or [50.00P].

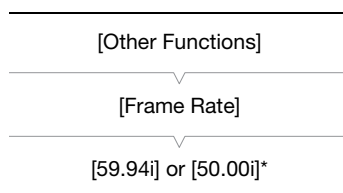

* Depending on the country/region of purchase.

Selecting the Resolution

- 1 Open the [Resolution] submenu.
[Other Functions] ➤ [Resolution]
- 2 Select the desired option and then press the joystick.

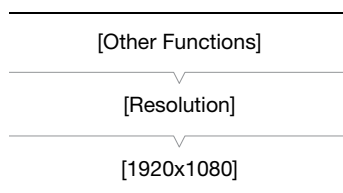

Available video configuration settings

Resolution	System frequency / Frame rate						
	59.94 Hz				50.00 Hz		
	59.94P	59.94i	29.97P	23.98P	50.00P	50.00i	25.00P
1920x1080	●	●	●	●	●	●	●
1280x720	●	–	●	●	●	–	●

Adjusting Main Camera Functions with the Joystick

Using only the joystick, you can adjust the following main camera functions. Note that some of the functions cannot be adjusted manually when the camera mode is set to [Auto].

- Camera mode (📖 33)
- Aperture (📖 34)
- Gain (📖 37)
- Shutter speed (📖 38)
- ND filter level (📖 39)
- White balance (📖 40)

32

This section will explain the basics of how to adjust the functions. For specific details, refer to each function's section.

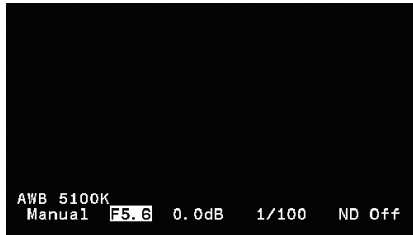

1 Press the joystick.

- The onscreen display of the function to be adjusted will be highlighted in orange.
- The display will return to normal if no operation is performed for about 6 seconds.

2 Push the joystick left/right to select the function you want to adjust.

3 Push the joystick up/down to select the desired option and then press the joystick.

- The desired option will be set and the display will return to normal.

NOTES

- The camera will automatically end the direct setting mode in the following cases.
 - If no operation was performed for more than 6 seconds.
 - If the MENU button or CANCEL button was pressed.

Setting the Camera Mode: Auto and Manual Modes

The camera allows you to choose between [Auto] and [Manual] camera modes. When the camera mode is set to [Auto], the camera performs automatic exposure by automatically adjusting the aperture, gain, shutter speed, ND filter level and white balance. Oppositely, when the camera mode is set to [Manual], you can adjust those settings manually.

By default, the camera mode is set to [Auto]. As such, the camera mode will be set to [Auto] the first time you use the camera or after you reset all the camera's settings.



[Auto] mode



[Manual] mode

- 1 Press the joystick.
 - One of the adjustable settings will be highlighted in orange on the screen.
- 2 Push the joystick left/right to select the current camera mode.
- 3 Push the joystick up/down to select the desired camera mode and then press the joystick.

NOTES

- When the camera mode is set to [Auto], the camera automatically adjusts the ND filter level by default. However, you can set the [Camera Setup] ➤ [ND Mode] to [Manual] setting to allow you to manually adjust the ND filter level.
- When the camera mode is set to [Auto] and the brightness changes, exposure adjustment may not be smooth.
- You can use the [Camera Setup] ➤ [AE Response] setting to change how quickly the aperture changes during automatic exposure when the camera mode is set to [Auto] or when you are using push auto iris.

Adjusting the Aperture

When the camera mode is set to [Manual], the camera offers the following two ways to adjust the aperture but available aperture values will vary depending on the lens attached.

Manual aperture: Adjust the aperture value manually using the joystick.

Push Auto Iris*: Momentary automatic aperture. Press a button to temporarily adjust the aperture automatically.

The camera also allows you to compensate for the exposure obtained during automatic exposure as well as select the light metering mode.

Manual Aperture

- 1 Set the camera mode to [Manual] (☰ 33).
- 2 Press the joystick.
 - One of the adjustable settings will be highlighted in orange on the screen.
- 3 Push the joystick left/right to select the current aperture value.
- 4 Push the joystick up/down to select the desired value and then press the joystick.

NOTES

- When using an EF lens that can correct the aperture value according to the position of the zoom, you can use the [Camera Setup] ➤ [Zoom-Iris Correct.] setting to activate this correction.
- When an optional RC-V100 Remote Controller is connected to the camera, you can adjust the aperture with the remote controller's IRIS dial. At default settings, turn the dial right to open up the aperture and left to close the aperture. Refer to the instruction manual of the RC-V100 for details on changing that setting.

Momentary Automatic Aperture - Push Auto Iris

You can have the camera temporarily take control and automatically adjust the aperture for an optimal exposure while you keep the button held down.

- 1 Set the camera mode to [Manual] (☰ 33).
- 2 Set an assignable button to [Push Auto Iris].
[Other Functions] ➤ [Assignable Buttons] ➤ Desired button ([1] to [4 (Remote)]) ➤ [Push Auto Iris]
- 3 Press and hold the assignable button.
 - The camera will automatically adjust the aperture to obtain optimal exposure.
 - When you release the button, automatic aperture mode will end and the aperture value that was last set with push auto iris will be maintained in manual aperture.

NOTES

- You can use the [Camera Setup]  [AE Response] setting to change how quickly the aperture changes during automatic exposure when the camera mode is set to [Auto] or when you are using push auto iris.
- When an optional RC-V100 Remote Controller is connected to the camera, you cannot use push auto iris while using the remote controller's FOCUS dial.

Exposure Compensation - AE Shift

You can compensate the exposure obtained during automatic exposure when the camera mode is set to [Auto] or after having used push auto iris, in order to darken or lighten the image.

1 Open the [AE Shift] submenu.

[Camera Setup]  [AE Shift]

2 Select an AE shift level and then press the joystick.

- When the camera mode is set to [Auto], you can check the effects of the selected AE shift level on the screen.
- You can select a level from -2.0 EV to 2.0 EV (in 0.25-EV increments).

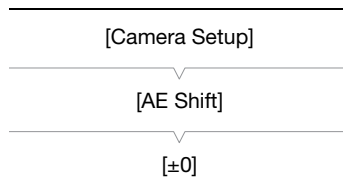

Available AE shift levels

+2.0	+1.75	+1.5	+1.25	+1.0	+0.75	+0.5	+0.25	±0
-0.25	-0.5	-0.75	-1.0	-1.25	-1.5	-1.75	-2.0	

NOTES

- If you set an assignable button to [AE Shift +] or [AE Shift -] ( 48), you can press the button to adjust the AE shift level.

Light Metering Mode

Select the light metering mode to match the shooting conditions. Using the appropriate setting will produce a suitable exposure level during automatic exposure when the camera mode is set to [Auto] or when you are using push auto iris.

1 Open the [Light Metering] submenu.

[Camera Setup]  [Light Metering]

2 Select the desired option and then press the joystick.

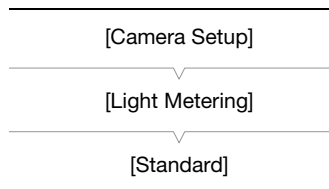

Options

[Backlight]: Suitable when shooting backlit scenes.

[Standard]: Averages the light metered from the entire screen, giving more weight to the subject in the center.

[Spotlight]: Use this option when shooting a scene in which only a certain part of the picture is lit, for example, when the subject is lit by a spotlight.

NOTES

- When the camera mode is set to [Manual], changing the light metering mode will not affect the exposure. In such case, a suitable exposure level may not be produced.

Gain

When the camera mode is set to [Manual], you can manually adjust the gain to change the brightness of the image. When the camera mode is set to [Auto], the camera will automatically adjust the gain. In such case, you can set an automatic gain control (AGC) limit to prevent the camera from using gain values above the preset limit.

Manual Adjustment

- 1 Set the camera mode to [Manual] (📖 33).
- 2 Press the joystick.
 - One of the adjustable settings will be highlighted in orange on the screen.
- 3 Push the joystick left/right to select the current gain value.
- 4 Push the joystick up/down to select the desired value and then press the joystick.
 - You can select a value from 0.0 to 75.0 dB (in 3.0-dB increments).
 - The selected value will be applied to the image on the screen.

NOTES

- When high gain levels are set, the picture may flicker slightly.
- When high gain levels are set, bright red, green or blue dots may appear on the screen. In such case, use a faster shutter speed (📖 38) or select a lower gain value.
- When an optional RC-V100 Remote Controller is connected to the camera, you can adjust the gain value with the remote controller's ISO/GAIN ▲/▼ buttons.

Auto Gain Control (AGC) Limit

- 1 Set the camera mode to [Auto].
- 2 Open the [AGC Limit] submenu.
[Camera Setup] ▶ [AGC Limit]
- 3 Select the desired level and then press the joystick.
 - You can select a level from 75 dB to 36 dB (in 3-dB increments).

[Camera Setup]

[AGC Limit]

[Off (75dB)]

Shutter Speed

Set the shutter speed based on shooting conditions. For example, you may want to set slower shutter speeds for darker environments.

- 1 Set the camera mode to [Manual] (📷 33).
- 2 Press the joystick.
 - One of the adjustable settings will be highlighted in orange on the screen.
- 3 Push the joystick left/right to select the current shutter speed value.
- 4 Push the joystick up/down to select the desired value and then press the joystick.

Available Shutter Speeds

The available shutter speeds vary depending on the system frequency and frame rate used.

System frequency / Frame rate				
59.94 Hz			50.00 Hz	
59.94P/59.94i	29.97P	23.98P	50.00P/50.00i	25.00P
1/4, 1/5, 1/6, 1/7, 1/8, 1/10, 1/12, 1/15, 1/17, 1/20, 1/24, 1/30, 1/34, 1/40, 1/48, 1/60, 1/75, 1/90, 1/100, 1/120, 1/150, 1/180, 1/210, 1/250, 1/300, 1/360, 1/420, 1/500, 1/600, 1/720, 1/840, 1/1000, 1/1200, 1/1400, 1/1700, 1/2000		1/3, 1/4, 1/5, 1/6, 1/7, 1/8, 1/10, 1/12, 1/15, 1/17, 1/20, 1/24, 1/30, 1/34, 1/40, 1/48, 1/60, 1/75, 1/90, 1/100, 1/120, 1/150, 1/180, 1/210, 1/250, 1/300, 1/360, 1/420, 1/500, 1/600, 1/720, 1/840, 1/1000, 1/1200, 1/1400, 1/1700, 1/2000		1/3, 1/4, 1/5, 1/6, 1/7, 1/8, 1/10, 1/12, 1/14, 1/16, 1/20, 1/25, 1/29, 1/33, 1/40, 1/50, 1/60, 1/75, 1/90, 1/100, 1/120, 1/150, 1/180, 1/210, 1/250, 1/300, 1/350, 1/400, 1/500, 1/600, 1/700, 1/800, 1/1000, 1/1200, 1/1400, 1/1600, 1/2000

NOTES

- When an optional RC-V100 Remote Controller is connected to the camera, you can change the shutter speed with the remote controller's SHUTTER ▲/▼ buttons.
- **About reducing flicker due to shooting under artificial light sources:**
 - When shooting under artificial light sources such as fluorescent, mercury or halogen lamps, the image may flicker depending on the shutter speed. In such case, you can use the [Camera Setup] ➤ [Flicker Reduction] setting to have the camera automatically detect and possibly reduce flicker.
 - Alternatively, you may be able to avoid flicker by setting the shutter speed to a value matching the frequency of the local electrical system: 1/50* or 1/100 for 50 Hz systems, 1/60 or 1/120 for 60 Hz systems.
 - *May not be available depending on the frame rate.

ND Filter

Using the ND filter allows you to open up the aperture to obtain a shallower depth of field even when shooting in bright surroundings. You can also use the ND filter to avoid the soft focus caused by diffraction when using small apertures.

1 Set the camera mode to [Manual] (📖 33).

- Alternatively, you can leave the camera mode set to [Auto] and change the [Camera Setup] ➤ [ND Mode] setting to [Manual] to be able to adjust manually only the ND filter.

2 Press the joystick.

- One of the adjustable settings will be highlighted in orange on the screen.

3 Push the joystick left/right to select the current ND filter setting.

4 Push the joystick up/down to select the desired setting and then press the joystick.

Options

- [ND Off]: Select this option to not use the ND filter.
- [ND 1/8]: Reduces the amount of light by 3 stops (1/8 the amount of light).
- [ND 1/64]: Reduces the amount of light by 6 stops (1/64 the amount of light)

NOTES

- Depending on the scene, the color may change when turning the ND filter on/off. Setting a custom white balance (📖 41) may be effective in such case.
- When an optional RC-V100 Remote Controller is connected to the camera, you can select the ND filter setting with the remote controller's ND button. ND filter indicators 3 and 4 are not used.

White Balance

The camera uses an electronic white balance process to calibrate the picture and produce accurate colors under different lighting conditions. There are 4 methods of setting the white balance.





Auto white balance (AWB): The camera automatically adjusts the white balance to the optimal level.

Custom white balance: You can use a gray card or white object with no pattern to establish the white balance and save it to one of two custom white balance settings, [WB-A] or [WB-B]. When shooting under fluorescent lights, we recommend setting the custom white balance.

Preset white balance: Set the white balance to [Tung] (tungsten lighting) or [DyIt] (daylight). Preset white balance settings can be further fine-tuned within a range of -9 to 9.

Select color temperature: Set the white balance to [Kelv] (Kelvin) to select a color temperature between 2,000 K and 15,000 K (in 100 K increments).

NOTES

- The [Custom Picture]  [Fine Tuning]  [White Balance] settings in the custom picture file ( 50) take precedence over the white balance set with these procedures.
- You can use the [Camera Setup]  [Shockless WB] setting to make the transition look smoother when you change the white balance settings.
- When an optional RC-V100 Remote Controller is connected to the camera, you can adjust the white balance with the remote controller's AWB button, A button, B button, PRESET button and  button.
- The color temperatures displayed on the screen are approximate. Use them only as a reference.

Auto White Balance (AWB)

The camera constantly adjusts the white balance automatically to achieve an optimal level. The camera will adjust the white balance if the light source changes.

- 1 Set the camera mode to [Manual] ( 33).
- 2 Press the joystick.
 - One of the adjustable settings will be highlighted in orange on the screen.
- 3 Push the joystick left/right to select the current white balance setting.
- 4 Push the joystick up/down to select [AWB] and then press the joystick.
 - The white balance will be adjusted automatically.

NOTES

- Custom white balance may provide better results in the following cases:
 - Changing lighting conditions
 - Close-ups
 - Subjects in a single color (sky, sea or forest)
 - Under mercury lamps and certain types of fluorescent and LED lights

Custom White Balance

- 1 Set the camera mode to [Manual] (📖 33).
- 2 Press the joystick.
 - One of the adjustable settings will be highlighted in orange on the screen.
- 3 Push the joystick left/right to select the current white balance setting.
- 4 Push the joystick up/down to select [WB-A] or [WB-B] and then press the joystick.
 - If a custom white balance has been stored previously, pressing the joystick will apply the stored custom white balance. You do not need to perform the rest of the procedure.
 - If a custom white balance has not yet been stored, the custom white balance display [WB-A] or [WB-B] and default value will flash slowly. Continue the procedure to establish the custom white balance.
- 5 Point the camera at a gray card or white object so that it fills the whole screen.
 - Use the same lighting conditions you plan to use when shooting.
- 6 Press the SET WB button.
 - [WB-A] or [WB-B] will flash quickly.
 - Make sure the gray card or white object fills the screen until the procedure is completed.
 - Once [WB-A] or [WB-B] stops flashing, the procedure is completed. The setting is retained even if you turn off the camera.

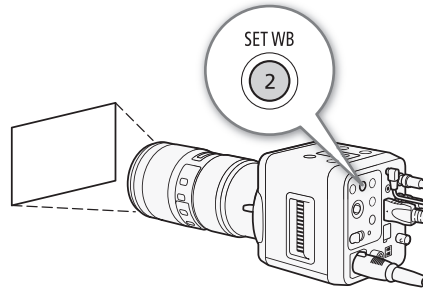

NOTES

- Readjust the custom white balance if the light source or ND filter setting changes.
- Very rarely and depending on the light source, [WB-A] or [WB-B] may keep flashing (it will change to a slow flashing). The result will still be better than with the auto white balance.
- The custom white balance will be reset after using either option in the [Other Functions] ➤ [Reset] setting.

Color Temperature/Preset White Balance

- 1 Set the camera mode to [Manual] (📖 33).
- 2 Press the joystick.
 - One of the adjustable settings will be highlighted in orange on the screen.
- 3 Push the joystick left/right to select the current white balance setting.
- 4 Push the joystick up/down to select [Kelv] (color temperature setting), or [DyIt] or [Tung] (preset white balance) and then press the joystick.
 - To change the color temperature or to further adjust the preset white balance, continue to step 5. If not, the rest of the procedure is not necessary.

5 Push the joystick right.

- Alternatively, you can press the SET WB button.
- **Color temperature:** On the screen, the default color temperature value (5,500 K) next to the white balance setting will be highlighted in orange.
Preset white balance: On the screen, the adjustment value ± 0 will appear next to the white balance setting, highlighted in orange.

6 Push the joystick up/down to change the color temperature or adjustment value and then press the joystick.

Adjusting the Focus

The camera offers the following ways to focus.

Manual focus: Turn the focus ring on the lens to adjust the focus. The lens's focus mode switch can be set to MF or AF*.

One-shot AF:** When the lens's focus mode switch set to AF, you can press an assignable button set to [One-Shot AF] to let the camera focus automatically.

* Depending on the lens, the focus ring may be disabled when the focus mode switch is set to AF.

**Not available when a manual focus lens is attached to the camera.

Manual Focus

Focus manually using the focus ring on the lens.

- 1 **Set the focus mode switch on the lens to MF.**
 - When using the optional RC-V100 Remote Controller to adjust the focus, set the focus mode switch to AF instead.
- 2 **Turn the lens's focus ring to adjust the focus.**

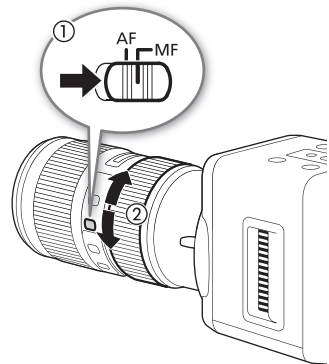

i NOTES

- With some EF lenses, you may be able to operate the focus ring even when the focus mode switch is set to AF.
- If you operate the zoom after focusing, the focus on the subject may be lost.
- When adjusting the focus, be careful not to touch the front of the lens or moving parts on the lens except for the focus ring.
- When an optional RC-V100 Remote Controller is connected to the camera, you can adjust the focus with the remote controller's FOCUS dial. At default settings, turn the dial right to focus farther and left to focus nearer. Refer to the instruction manual of the RC-V100 for details on changing that setting.

One-Shot AF

With one-shot AF, the camera will be able to focus automatically while you press and hold down a single button.

- 1 **Set the focus mode switch on the lens to AF.**
- 2 **Set an assignable button to [One-Shot AF].**
[Other Functions] ➤ [Assignable Buttons] ➤ Desired button ([1] to [4 (Remote)]) ➤ [One-Shot AF]
- 3 **Press and hold the assignable button.**
 - While the camera is trying to focus on a subject, [AF] will flash quickly on the left of the screen. When the correct focus has been achieved, it will stop flashing and stay on.
 - When one-shot AF is not available or the camera cannot focus on a subject, [AF] will flash in red on the screen.
 - [AF] will disappear when you release the assignable button.

i NOTES

- One-shot AF is not available for the following shutter speed settings.
 - 1/4, 1/5, 1/6 (at a system frequency of 59.94 Hz with a frame rate other than 23.98P)
 - 1/3, 1/4, 1/5 (at a system frequency of 59.94 Hz with a frame rate of 23.98P)
 - 1/3, 1/4, 1/5 (at a system frequency of 50.00 Hz)
- Autofocus may not work well on the following subjects or in the following cases. In such case, focus manually.
 - Reflective surfaces
 - Subjects with low contrast or without vertical lines
 - Fast moving subjects
 - Through dirty or wet windows
 - Low-light scenes
 - Subjects with a repetitive pattern

Focus Limit: Setting the Distance Range for Autofocus

You can set a "focus limit" range for the attached lens, which will cause the camera to try to autofocus (with one-shot AF) on subjects only within that range, thereby possibly reducing autofocusing time. You can set the far end and near end of the range, as necessary, by selecting a desired focus position.

1 Open the [Activate] submenu to activate the focus limit.

[Camera Setup] ➤ [Focus Limit] ➤ [Activate]

2 Select [On] and then press the joystick.

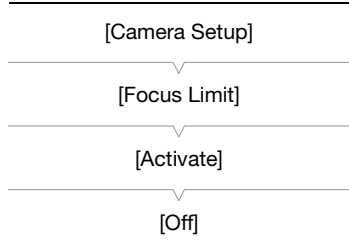

To set the far end of the range

3 Adjust the focus to the desired position for the far end of the range.

4 Open the [Far] focus limit submenu.

[Camera Setup] ➤ [Focus Limit] ➤ [Far]

- When a focus limit has not been set, [Limit Off] will appear on the [Focus Limit] submenu screen. When it has been set, [Limit On] will appear.

5 Select [Set] and then press the joystick.

- Select [Reset] instead to clear the focus position currently set for the far end.
- Select [Cancel] instead to cancel the operation.

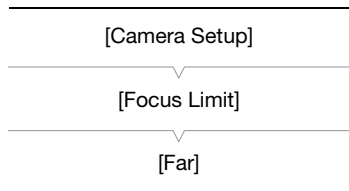

To set the near end of the range

3 Adjust the focus to the desired position for the near end of the range.

4 Open the [Near] focus limit submenu.

[Camera Setup] ➤ [Focus Limit] ➤ [Near]

- When a focus limit has not been set, [Limit Off] will appear on the [Focus Limit] submenu screen. When it has been set, [Limit On] will appear.

5 Select [Set] and then press the joystick.

- Select [Reset] instead to clear the focus position currently set for the near end.
- Select [Cancel] instead to cancel the operation.

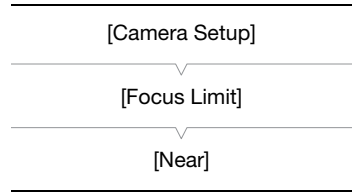

NOTES

- If the limits for the near end and far end conflict, the one most recently set will take precedence and the other will be cleared. For example, if you set a limit for the far end and then you set one for the near end that is further, the limit for the far end will be cleared.
- When you activate one-shot AF after setting a focus limit, if no subject can be focused on within the range, the focus will return close to the position where it was prior to activating one-shot AF.
- If you operate the zoom after setting a focus limit, the position of the focus limit will change. Set the focus limit again.

Infrared Mode

Using the infrared mode, the camera becomes more sensitive to infrared light, allowing you to shoot in dark locations. During infrared mode, only some functions are available for adjustment.

1 Open the [Infrared] submenu.

[Camera Setup] ➤ [Infrared]

2 Select [On] and then press the joystick.

[Camera Setup]

[Infrared]

[Off]

46

Functions available during infrared mode

Refer to the following table for a summary of functions available for adjustment.

Function	Status
Camera mode, aperture, gain, shutter speed, focus	Available for adjustment as described in previous sections.
White balance	Available for adjustment only by using the [Custom Picture] ➤ [Fine Tuning] ➤ [White Balance] setting when a custom picture file is selected. Otherwise, not available for adjustment.
ND filter level	Turned off and not available for adjustment.
Light metering	Set to [Standard] and not available for adjustment.

NOTES

- Depending on the light source, autofocus may not work well during infrared mode.

Using the Optional RC-V100 Remote Controller

You can connect the optional RC-V100 Remote Controller to control the camera from a distance. In addition to turning the camera on and off and navigating the menu, you can control various shooting-related functions, such as aperture, shutter speed, and custom picture settings, like knee and sharpness. For details on how to connect and use the remote controller, refer to its instruction manual. Visit your local Canon Web site to download the latest version.

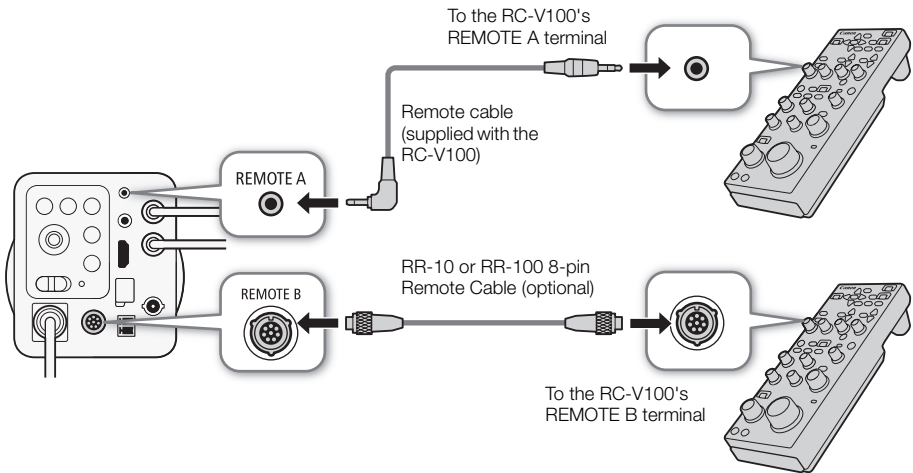

- 1 Set the **POWER** switch to OFF and connect the remote controller to the camera.
- 2 Set the **POWER** switch to ON.

i NOTES

- The following controls on the remote controller will not operate the camera: ONSCREEN button, REC REVIEW button, SHUTTER SELECT button, AGC button, AUTO KNEE button, AF button, AUTO IRIS button and ZOOM dial.
- If you plan on connecting the optional RC-V100 Remote Controller to the camera using the optional RR-10 or RR-100 8-pin Remote Cable, check the serial number of the RC-V100. If the serial number starts with "01 xxxx" (where xxxx represents other digits), you will need to update the remote controller's firmware. Canon will perform this feature upgrade, and requires that RC-V100 Remote Controller be sent to an accredited Canon service center. Shipping and handling charges may apply. Contact a Canon Customer Support Center for details.
- When connecting the optional RC-V100 Remote Controller to the camera, make sure that the remote controller's terminal selection switch is set to match the terminal to be used on the camera.

Assignable Buttons

The camera offers three assignable buttons to which you can assign various functions. Assign often-used functions to personalize the camera to your needs and preferences. When an optional RC-V100 Remote Controller is connected to the camera, you can use a fourth assignable button. The names of the buttons printed on the camera also indicate the buttons' default settings.

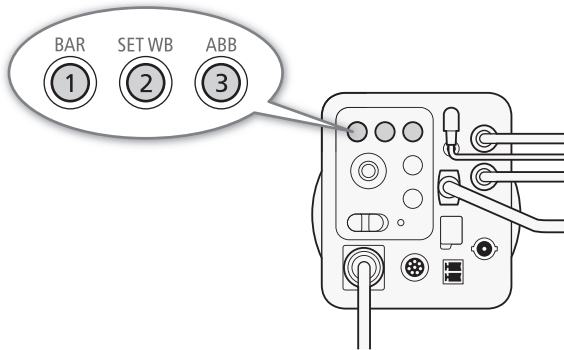

Changing the Assigned Function

- 1 Open the [Assignable Buttons] submenu.
[Other Functions] ➤ [Assignable Buttons]
- 2 Select the button to change and then press the joystick.
 - A list of available functions appears.
- 3 Select the desired function and then press the joystick.
 - The selected function will be assigned to the selected button.

[Other Functions]

[Assignable Buttons]

[1 Color Bars]
 [2 Set WB]
 [3 ABB]
 [4 (Remote) Infrared]*

* Assignable button 4 is located on the optional RC-V100 Remote Controller but the button's function can be assigned without connecting the RC-V100 to the camera.

Using an Assignable Button

After you assign a function to one of the buttons, press the button to activate the function. For some functions, you may need to perform other procedures. Refer to the function's reference page below, as necessary.

Assignable Functions

Function name	Description	
[One-Shot AF]	The camera automatically focuses (one-shot AF function) while the button is held pressed down.	43
[Push Auto Iris]	The camera automatically adjusts the aperture only while the button is held pressed down.	34
[ABB]	Starts the procedure for automatic black balance adjustment.	22
[AE Shift +]	Compensates the exposure making the image brighter.	35
[AE Shift -]	Compensates the exposure making the image darker.	
[Color Bars]	Turns color bars on/off.	28
[Set WB]	Enters the direct setting mode with the white balance highlighted and ready to be adjusted.	40
[Tele-converter]	Activates the digital tele-converter in the following sequence: 2x → 4x → Off	-
[Infrared]	Turns infrared mode on/off.	46
[External Rec]	Outputs a recording command to an external recorder to start or stop recording.	55
[Custom Picture]	Opens the [Custom Picture] submenu.	50
[Camera Mode A/M]	Switches the camera mode between [Auto] and [Manual] .	33

Custom Picture Settings

The camera lets you change several settings (📖 51) that control various aspects of the image produced. As a set, all these settings are treated as a single custom picture file. After adjusting the desired settings to your preference, you can save up to six custom picture files in the camera and load them later to apply exactly the same settings. Alternatively, you can use one of the three preset custom picture files.

NOTES

- Custom picture files are exclusively compatible for use only with ME20F-SH cameras.

Selecting Custom Picture Files

Select a custom picture file to apply its settings while shooting or to edit it.

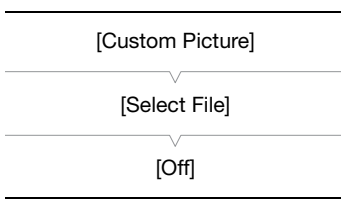

1 Open the custom picture file's [Select File] screen.

[Custom Picture] ➤ [Select File]

- If you set an assignable button to [Custom Picture] (📖 48), you can press the button to open the [Custom Picture] submenu.
- Alternatively, when the optional RC-V100 Remote Controller is connected to the camera, you can press the remote controller's CUSTOM PICT. button to open the [Custom Picture] submenu.

2 Push the joystick up/down to select the desired file and then press the joystick.

- Select one of the custom picture files saved in the camera ([CP1] to [CP6], [EOS Std.], [Wide DR], [Canon Log]).
- When you close the menu, the selected custom picture file's settings will be applied.

Preset Custom Picture Files

The following describes the preset files.

- [EOS Std.]: Reproduces the image quality and look (vivid, sharp and crisp) of an EOS digital SLR camera with its picture style set to [Standard].
- [Wide DR]: Applies a gamma curve with a very wide dynamic range and an appropriate color matrix that nevertheless do not require post-production processing.
- [Canon Log]: Uses the Canon Log gamma and color matrix for an outstanding dynamic range and an image suitable for processing in post-production.

NOTES

- **About changing custom picture related settings using the optional RC-V100 Remote Controller**
 - Adjusting custom picture related settings using the remote controller will change the settings registered under the currently selected custom picture file.
 - If a preset custom picture file is selected, custom picture settings cannot be changed using the remote controller.

Editing a Custom Picture File's Settings

- 1 After selecting a file, select [Fine Tuning] and then press the joystick.
- 2 Select a setting and then press the joystick.
- 3 Change the setting to the desired level and then press the joystick.
 - Refer to *Available Custom Picture Settings* (□ 51) for details on the various settings.
 - Repeat steps 2 and 3 for other settings, as necessary.
- 4 Press the MENU button to exit the custom picture menu and apply the new custom picture settings.

Resetting the Current File's Settings to Default Values

- 1 After selecting a file, open the [Reset] submenu.
- 2 Select the desired default values and then press the joystick.
 - Select [Neutral] to reset to neutral default values (equivalent to not using custom picture settings at all) or one of the preset settings ([EOS Std.], [Wide DR] or [Canon Log]) if you want to replicate these preset settings, for example as a starting point to edit them further.
- 3 Select [OK] and then press the joystick.
 - After resetting the file's values, you can continue to adjust the settings or press MENU twice to close the menu.

Available Custom Picture Settings

[Gamma]

The gamma curve changes the overall look of the image. (Default: [Normal 1])

- [Normal 1]: Standard picture for playback on TV monitors.
- [Normal 2]: Setting suitable for playback on TV monitors. Produces brighter highlights (bright areas of the image) than with the [Normal 1] setting.
- [Normal 3]: Setting suitable for playback on TV monitors. Produces a more faithful black gradation in the shadows (dark areas of the image) than with the [Normal 2] setting.
- [Normal 4]: Setting suitable for playback on TV monitors. Produces even better black gradation in the shadows (dark areas of the image) than with the [Normal 3] setting.
- [EOS Std.]: This gamma curve approximates the look of an EOS digital SLR camera when the picture style is set to [Standard] . Produces higher contrast than with the [Normal 1] setting.
- [Wide DR]: Gamma curve with a very wide dynamic range. Optimized for playback on TV monitors.
- [Canon Log]: Logarithmic gamma curve that obtains an impressive dynamic range and makes the most of the image sensor characteristics. Requires image processing in post-production.

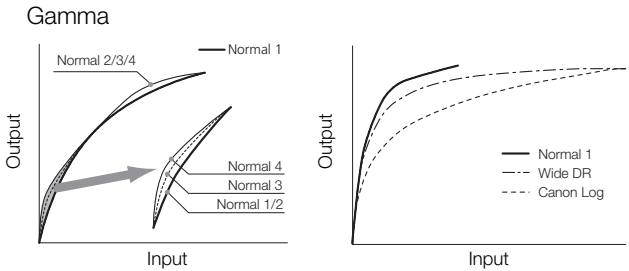

[Black] ➤ [Master Pedestal]

The master pedestal increases or decreases the black level. Higher settings will make dark areas brighter but decrease contrast. This setting can be adjusted from -50 to 50. (Default: ±0)

[Black] ➤ [Master Black Red], [Master Black Blue]

These settings correct the color cast in blacks. Each can be adjusted from -50 to +50. (Default: ±0)

[Black Gamma]

Raises or lowers the lower part of the gamma curve (dark areas of the image). This setting can be adjusted from -50 to 50. (Default: ±0) When [Gamma] is set to [Wide DR] or [Canon Log], this setting has no effect on the picture.

Black Gamma

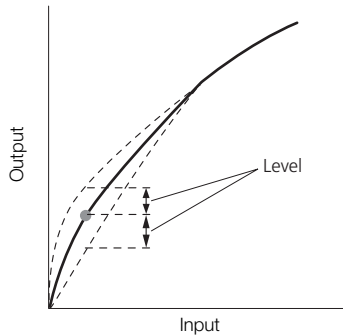

[Knee]

Controls the upper part of the gamma curve (highlights of the image). By compressing the highlights, you can prevent parts of the image from being overexposed. When [Gamma] is set to [EOS Std.], [Wide DR] or [Canon Log], this setting has no effect on the picture.

[Activate]: Activates/deactivates the setting. (Default: [On])

[Slope]: Determines the slope of the gamma curve above the knee point. This setting can be adjusted from -35 to 50. (Default: ±0)

[Point]: Sets the knee point of the gamma curve. This setting can be adjusted from 50 to 109. (Default: 95)

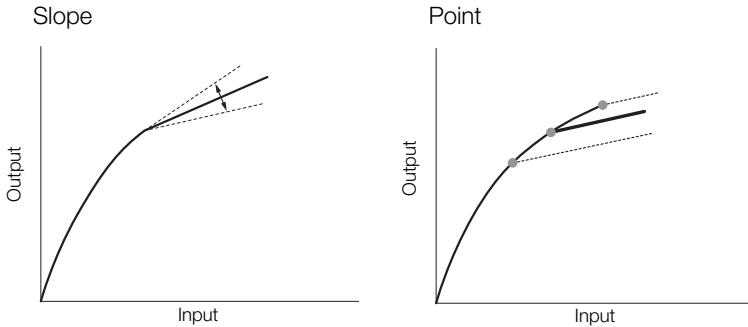
**[Sharpness]**

Sets the sharpness level. This setting can be adjusted from -10 to 50 . (Default: ± 0)

[Noise Reduction]

Reduces the amount of noise that appears in the image. Select a level from 1 (lowest level) to 12 (highest level), or select [Off] to turn the noise reduction off. (Default: [Off])

[White Balance]

Adjusts the amount of white balance throughout the whole image.

[R Gain]: Adjust the intensity of red tones. This setting can be adjusted from -50 to 50 . (Default: ± 0)

[B Gain]: Adjust the intensity of blue tones. This setting can be adjusted from -50 to 50 . (Default: ± 0)

i NOTES

- When an optional RC-V100 Remote Controller is connected to the camera, the following custom picture settings can be changed using the buttons and dials on the remote controller.
 - [Black] ➤ [Master Pedestal], [Master Black Red], [Master Black Blue]
 - [Black Gamma]
 - [Knee] ➤ [Slope], [Point]
 - [Sharpness]
 - [White Balance] ➤ [R Gain], [B Gain]

Customizing Onscreen Displays

Custom displays allow you to adjust the onscreen displays that appear. For details on which onscreen displays can be customized and the setting options, refer to *Onscreen Displays* (📖 28) and [Custom Display] (📖 63).

54

- 1 Open the [Custom Display] submenu.
[Other Functions] ➤ [Custom Display]
- 2 Select the desired onscreen display.
- 3 Change the setting option and then press the joystick.

[Other Functions]

[Custom Display]

5 External Connections

Connecting to an External Recorder

Connect the camera to an external recorder using the 3G/HD-SDI 1 / MONITOR terminal, 3G/HD-SDI 2 terminal or HDMI OUT terminal. Use the terminal on the camera that matches the one you wish to use on the external recorder. For details on compatible external recorders, consult the retail dealer from whom you purchased the camera or contact a Canon Service Center. For details on connecting the camera to an external monitor, refer to *Connecting to an External Monitor* (📖 18).

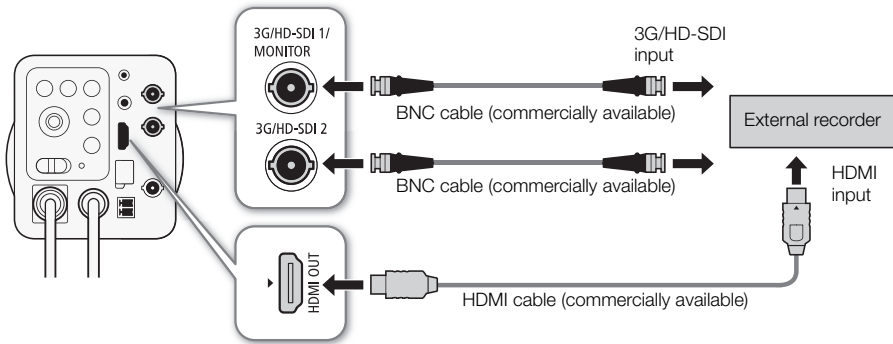

Outputting a Recording Command to an External Recorder

You can use an assignable button set to [External Rec] or an optional RC-V100 Remote Controller to output a recording command to an external recorder connected to the camera to start or stop recording.

1 Set an assignable button to [External Rec].

[Other Functions] ➤ [Assignable Buttons] ➤ Desired button ([1] to [4 (Remote)]) ➤ [External Rec]

2 Press the assignable button to output a recording command to start recording.

- Alternatively, when an optional RC-V100 Remote Controller is connected to the camera, you can press the remote controller's START/STOP button.
- While a recording command is being output, [Rec] will appear on the right of the screen.

3 Press the assignable button again to output a recording command to stop recording.

- [Rec] will disappear.

NOTES

- If the recording command does not seem to be output when you press the assignable button, make sure that the [Audio/Video Setup] ➤ [Rec Command] setting is set to [On].

- When a recording command has been sent and [Rec] appears on the screen, the following settings are not available to be changed.
 - [Camera Setup] ➤ [ABB]
 - [Audio/Video Setup] ➤ [3G-SDI Mapping], [Rec Command]
 - [Other Functions] ➤ [Reset], [Time Zone], [Set Clock] ➤ [Date/Time], [Assignable Buttons], [System Frequency], [Frame Rate], [Genlock Adjustment], [Resolution], [Camera Name]

Synchronizing with an External Device

Using genlock synchronization, you can synchronize this camera's video signal to that of an external video device. When a reference sync signal (analog blackburst or tri-level HD signal) is input through the GENLOCK terminal, the phases of the camera's V and H sync will automatically be synchronized to it. The phase difference between the external genlock signal and the camera is initially set to 0. The H phase can be adjusted within the range of approximately ± 0.4 H (-1023 to 1023) by following the procedure below.

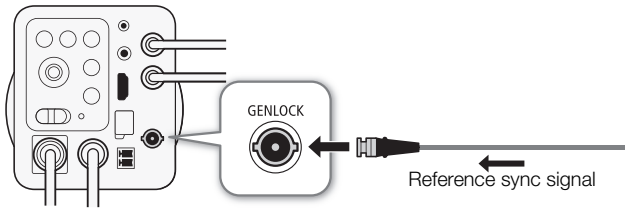

1 Open the [Genlock Adjustment] submenu.

[Other Functions] ➤ [Genlock Adjustment]

2 Push the joystick up/down to select the value of the first field and then press the joystick to move to the next field.

- Change the rest of the fields in the same way to select the desired adjustment level (-1023 to 1023).

3 Select [Set] and then press the joystick.

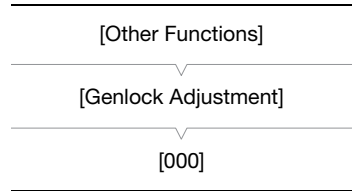

i NOTES

- When a suitable genlock signal is input, the genlock synchronization stabilizes within approximately 10 seconds.
- When a suitable genlock signal is detected, [Gen.] will flash on the upper right of the screen. When the camera locks on the external genlock signal, [Gen.] will stop flashing and stay on.
- If the external genlock signal is incorrect, the synchronization may not be stable.

Audio Input and Output

You can connect a commercially available microphone with a \varnothing 3.5 mm stereo mini plug to the MIC terminal. The audio from the external microphone will be output from the 3G/HD-SDI 1 / MONITOR terminal, 3G/HD-SDI 2 terminal and HDMI OUT terminal.

Audio Input

Connection Diagram

If you connect a commercially available plug-in power microphone (generally, an electret condenser microphone that requires external power), you will need to perform the procedure below to supply power to the MIC terminal.

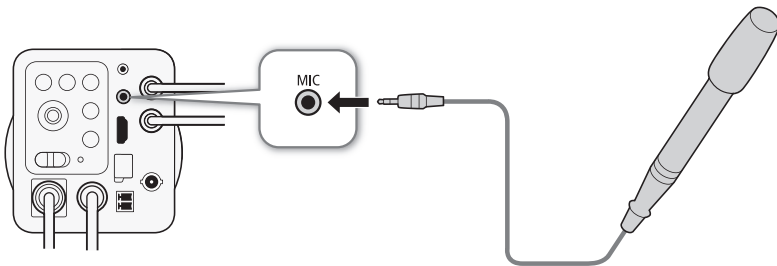

Supplying Power to a Plug-in Power Microphone

- 1 Open the [MIC Power] submenu.
[Audio/Video Setup] ➤ [MIC Power]
- 2 Select [On] and then press the joystick.

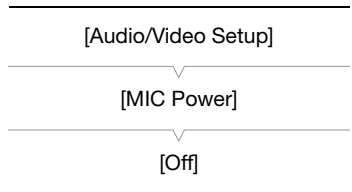

! IMPORTANT

- Supplying power to a microphone without plug-in power functionality may damage the microphone.

Audio Output

The camera features 2-channel linear PCM audio output. The sampling frequency is 48 kHz and the audio bit depth is 16 bit. The audio from the external microphone will be output with the video signal from the 3G/HD-SDI terminals and HDMI OUT terminal and can be recorded with an external recorder connected to the camera.

6 Additional Information

Menu Options

For details about how to select an item, refer to *Using the Menus* (📖 20). Setting options in boldface indicate default values.

Depending on the camera's settings, some menu items may not be available. Such menu items do not appear or appear grayed out in menu screens.

To skip directly to the page of a specific menu:

[Camera Setup] menu	📖 59
[Audio/Video Setup] menu	📖 61
[Custom Picture] menu	📖 61
[Other Functions] menu	📖 62

[Camera Setup] menu

Menu item	Submenu / Setting options
[Light Metering]	[Backlight], [Standard] , [Spotlight] Selects the light metering mode (📖 35). [Backlight]: Suitable when shooting backlit scenes. [Standard]: Averages the light metered from the entire screen, giving more weight to the subject in the center. [Spotlight]: Use this option when shooting a scene in which only a certain part of the picture is lit, for example, when the subject is lit by a spotlight.
[AE Shift]	[+2.0], [+1.75], [+1.5], [+1.25], [+1.0], [+0.75], [+0.5], [+0.25], [±0] , [-0.25], [-0.5], [-0.75], [-1.0], [-1.25], [-1.5], [-1.75], [-2.0] You can compensate the exposure obtained when the camera mode is set to [Auto] or when you are using push auto iris, in order to darken or lighten the image (📖 35).
[AE Response]	[High], [Normal] , [Low] Determines how quickly the aperture changes when the camera mode is set to [Auto] or when you are using push auto iris.
[AGC Limit]	[Off (75dB)] to [36dB] (in 3-dB increments) You can set an automatic gain control (AGC) limit to prevent the camera from using gain values higher than the preset limit when the camera mode is set to [Auto] (📖 37).
[Flicker Reduction]	[Automatic], [Off] Allows the camera to automatically detect and reduce flicker caused by artificial light sources.
[Shockless WB]	[On], [Off] When this setting is set to [On], makes the transition look smoother when the white balance is changed.

Menu item	Submenu / Setting options
[Zoom-Iris Correct.]	<p>[On], [Off]</p> <p>If you are using a compatible lens, when this setting is set to [On], the camera will adjust the aperture as needed to keep the selected aperture value while zooming. Because of this adjustment, the brightness of the image might change slightly or you may hear the operation sound. When this setting is set to [Off], the aperture will close gradually as you zoom but you will not hear the aperture's operation sound.</p>
[Focus Limit]	<p>[Activate] [On], [Off]</p> <p>Turns the focus limit on/off (☞ 44).</p>
	<p>[Far] [Set], [Reset], [Cancel]</p> <p>Allows you to set the far end of the focus limit for the attached lens (☞ 44). When a focus limit has not been set, [Limit Off] will appear on the submenu screen.</p> <p>[Set]: Saves the current focus position for the far end of the focus limit. [Reset]: Clears the currently set focus position. [Cancel]: Cancels the operation.</p>
	<p>[Near] [Set], [Reset], [Cancel]</p> <p>Allows you to set the near end of the focus limit for the attached lens (☞ 44). When a focus limit has not been set, [Limit Off] will appear on the submenu screen.</p> <p>[Set]: Saves the current focus position for the near end of the focus limit. [Reset]: Clears the currently set focus position. [Cancel]: Cancels the operation.</p>
[Tele-converter]	<p>[4x], [2x], [Off]</p> <p>Allows you to digitally increase the focal length of the camera by a factor of approx. 2 or 4. Note that the image is digitally processed so the image will deteriorate throughout the zoom range.</p>
[EF-S Lens]	<p>[On], [Off]</p> <p>When this setting is set to [On], reduces the peripheral illumination fall-off or vignetting that may occur when using an EF-S lens with this camera. However, the image is digitally enlarged by a factor of approx. 1.48 so the image will deteriorate.</p>
[ABB]	<p>[Cancel], [OK]</p> <p>Starts the procedure to adjust the black balance automatically (☞ 22).</p>
[Color Bars]	<p>[Activate] [On], [Off]</p> <p>Turns color bars on/off.</p>
	<p>[Type] [SMPTE], [ARIB] (when the system frequency is 59.94 Hz) [EBU], [SMPTE] (when the system frequency is 50.00 Hz)</p> <p>Selects the type of color bars. The default setting depends on the country/region of purchase.</p>
[Infrared]	<p>[On], [Off]</p> <p>Turns infrared mode on/off (☞ 46).</p>

Menu item	Submenu / Setting options
[ND Mode]	<p>[Automatic], [Manual]</p> <p>Determines how the ND filter level is adjusted when the camera mode is set to [Auto].</p> <p>[Automatic]: The ND filter level is adjusted automatically by the camera.</p> <p>[Manual]: The ND filter level is adjusted manually (☞ 39).</p>
[Periph.Illum.Corr.] (Peripheral illumination correction)	<p>[On], [Off]</p> <p>When this setting is set to [On] and the camera has correction data for the attached lens, it compensates for the darkening of the image's corners (peripheral illumination drop) due to the lens's characteristics (☞ 24).</p>

[Custom Picture] menu

Menu item	Submenu / Setting options
[Select File]	<p>[Off], [CP1] to [CP6], [EOS Std.], [Wide DR], [Canon Log]</p> <p>Selects a custom picture file to apply its settings while shooting or to edit it.</p>
[Fine Tuning]	See the detailed explanations on pages 51 to 53.

[Audio/Video Setup] menu

Menu item	Submenu / Setting options
[MIC Power]	<p>[On], [Off]</p> <p>When this setting is set to [On], the camera supplies power to a plug-in power microphone connected to the MIC terminal (☞ 58).</p> <p> IMPORTANT</p> <ul style="list-style-type: none"> Supplying power to a microphone without plug-in power functionally may damage the microphone.
[1kHz Tone]	<p>[-12dB], [-18dB], [-20dB], [Off]</p> <p>Outputs a 1-kHz audio reference signal from the 3G/HD-SDI terminals and HDMI OUT terminal.</p>
[3G-SDI Mapping]	<p>[Level A], [Level B]</p> <p>Allows you to select a 3G-SDI mapping level, as defined by the SMPTE ST 425-1 standard, for the output of the 3G/HD-SDI terminals.</p>
[Rec Command]	<p>[On], [Off]</p> <p>When this setting is set to [On], you can use an assignable button set to [External Rec] or an optional RC-V100 Remote Controller to output a recording command to an external recorder connected to the camera to start or stop recording (☞ 55).</p>

[Other Functions] menu

Menu item	Submenu / Setting options	
[Reset]	[All Settings]	[Cancel], [OK] Resets all the camera's settings to default settings, except for the hour meters displayed in the [Other Functions] ► [Reset Hour Meter] submenu.
	[Camera Settings]	[Cancel], [OK] Resets the white balance, iris, gain, shutter speed, ND filter, custom picture, focus limit and other shooting-related settings to default settings.
[Time Zone]	List of world time zones. [UTC-05:00 New York] or [UTC+01:00 Central Europe] Sets the time zone for the camera's clock. The default value depends on the country/region of purchase.	
[Set Clock]	[Date/Time]	– Sets the date and time for the camera's clock (☞ 19).
	[Date Format]	[YMD], [YMD/24H], [MDY] , [MDY/24H], [DMY] , [DMY/24H] Sets the date format and time format for the camera's clock. The default value depends on the country/region of purchase.
[Assignable Buttons]	[1] to [4 (Remote)]	[(NONE)], [One-Shot AF], [Push Auto Iris], [ABB] ([3]) , [AE Shift +], [AE Shift -], [Color Bars] ([1]) , [Set WB] ([2]) , [Tele-converter], [Infrared] ([4 (Remote)]) , [External Rec], [Custom Picture], [Camera Mode A/M] Allows you to assign a function to an assignable button. The number in parentheses above indicates the assignable button to which the default setting in bold next to it is assigned (☞ 48). Assignable button 4 is located on the optional RC-V100 Remote Controller but the button's function can be assigned without connecting the RC-V100 to the camera.
[Power LED]	[On] , [Off]	Allows you to set whether the POWER indicator illuminates while the camera is on.
[Fan Speed]	[Automatic] , [High], [Middle], [Low] Sets the cooling fan's speed. If you select [Automatic], the camera will adjust the speed of the cooling fan based on the camera's internal temperature.	
[System Frequency]	[59.94Hz] , [50.00Hz] Sets the camera's system frequency (☞ 31). The default value depends on the country/region of purchase.	
[Frame Rate]	[59.94P], [59.94i] , [29.97P], [23.98P] (when the system frequency is 59.94 Hz) [50.00P], [50.00i] , [25.00P] (when the system frequency is 50.00 Hz) Sets the camera's frame rate (☞ 31). The default value depends on the country/region of purchase.	
[Resolution]	[1920x1080] , [1280x720] Sets the camera's resolution (☞ 31).	

Menu item	Submenu / Setting options
[Genlock Adjustment]	[-1023] to [1023] ([000]) When using genlock synchronization, the phase difference between the external genlock signal and the camera is initially set to 0. This function allows you to adjust it within the range of approx. ± 0.4 H (-1023 to 1023) (📖 57).
[Scan Reverse]	[Both], [Vertical], [Horizontal], [Off] Inverts the image horizontally and/or vertically.
[Custom Display]	[Camera Name] [On] , [Off] Displays the name set for [Other Functions] ➤ [Camera Name] on the screen.
	[Date/Time] [Date/Time], [Time], [Date], [Off] Displays the date and/or time on the screen.
	[White Balance] [On] , [Off] Displays the white balance setting on the screen.
	[Camera Mode] [On] , [Off] Displays the camera mode ([Auto] or [Manual]) on the screen.
	[Iris] [On] , [Off] Displays the aperture value on the screen.
	[Gain] [On] , [Off] Displays the gain value on the screen.
	[Shutter Speed] [On] , [Off] Displays the shutter speed on the screen.
	[ND Filter/Infrared] [On] , [Off] Displays the ND filter setting and infrared mode status ([IR] indicates on) on the screen.
	[Custom Picture] [On] , [Off] Displays the currently selected custom picture file on the screen.
	[Lens Error] [On] , [Off] Displays [Lens] in red on the screen when a lens error occurs.
[Temperature Warning] [On] , [Off] Displays [Temp.] in red on the screen when a temperature warning occurs.	
[Camera Name]	[] (space), [A] to [Z], [a] to [z], numbers, special characters, [Set] Allows you to enter a name (up to 16 characters) to identify the camera. The camera name will appear on the screen by default. Push the joystick up/down to select the desired character and then press SET to move to the next field. You can press MENU to delete a character. When finished, select [Set] and then press SET.

Menu Options

Menu item	Submenu / Setting options
[Reset Hour Meter]	[Cancel], [OK] The camera has two “hour meters” – the first keeps track of total operation time and the second keeps track of operation time since the last time the second hour meter was reset with this setting.
[Initialize Media]	(For maintenance only.) Initializes the memory card used when updating the firmware. This menu option is usually unavailable.
[Firmware]	– You can verify the current version of the camera’s firmware. This menu option is usually unavailable.

Onscreen Warning Displays and Messages

Refer to this section if a warning display or message appears on the screen. Should the camera fail to operate correctly, consult a Canon Service Center.

[Temp.] appears in red on the screen.

- The camera's internal temperature has risen to a predetermined level. Set [Other Functions]  [Fan Speed] to [Automatic] or [High]. If [Temp.] continues to appear on the screen after a period of time, turn off the camera and wait until the temperature has decreased. If that does not solve the problem, consult a Canon Service Center.

[Fan] appears in red on the screen.

- The cooling fan may not be working properly. Consult a Canon Service Center.

[Lens] appears in red on the screen.

- There was a communication error between the camera and the lens. Turn the camera off and then on again. Alternatively, turn off the camera, remove the lens, and clean the lens's contact. Next, reattach the lens. If that does not solve the problem, consult a Canon Service Center.

[ABB error] appears on the screen.

- An error occurred while the camera was automatically adjusting the black balance. Make sure that the body cap is firmly attached to the camera blocking light from entering the camera. Next, perform the operation again. If that does not solve the problem, consult a Canon Service Center.

Built-in Rechargeable Lithium Battery

The camera has a built-in rechargeable lithium battery to keep the date/time and other settings. The built-in lithium battery is recharged while you use the camera; however, it will discharge completely if you do not use the camera for about 3 months.

To recharge the built-in lithium battery: Power the camera with an external power supply for 24 hours while the camera is turned off.

Maintenance/Others

Cleaning

Camera Body

- Use a soft, dry cloth to clean the camera's body. Never use chemically treated cloths or volatile solvents such as paint thinner.

Lens

- Remove any dust or dirt particles using a non-aerosol type blower.
- Use a clean, soft lens-cleaning cloth to gently wipe the lens. Never use tissue paper.

Condensation

Moving the camera rapidly between hot and cold temperatures may cause condensation (water droplets) to form on its internal surfaces. Stop using the camera if condensation is detected. Continued use may damage the camera.

Condensation may form in the following cases:

- When the camera is moved quickly from cold to warm places
- When the camera is left in a humid room
- When a cold room is heated rapidly

To avoid condensation

- Do not expose the camera to sudden or extreme changes in temperature.
- Place the camera in an airtight plastic bag and let it adjust gradually to temperature changes before removing it from the bag.

When condensation is detected

The precise time required for water droplets to evaporate will vary depending on the location and weather conditions. As a general rule, wait for 2 hours before resuming use of the camera.

Optional Accessories

The following optional accessories are compatible with this camera. The availability differs from area to area.

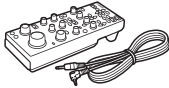

RC-V100
Remote Controller



RR-10 8-pin Remote Cable
(10 m, 32.8 ft.),
RR-100 8-pin Remote Cable
(100 m, 328 ft.)



TB-1 Tripod Adapter Base

For our customers in the USA: Call or visit your local retailer/dealer for genuine Canon video accessories. You can also obtain genuine accessories for your Canon camera by calling: 1-800-828-4040, Canon U.S.A. Information Center.

Use of genuine Canon accessories is recommended.

This product is designed to achieve excellent performance when used with genuine Canon accessories.



This mark identifies genuine Canon video accessories.

Specifications

ME20F-SH

System

68

- **Image Sensor**
35mm full-frame CMOS sensor
Effective pixels (approximate): 2,260,000 pixels
- **Minimum subject illumination (ISO 4,000,000 equivalent)**
Less than 0.0005 lux¹
¹ Under the following conditions: color, no light accumulation, f/1.2, 30P, 50 IRE, maximum gain 75 dB.
- **Lens Mount:** Canon EF lens mount (Cinema Lock type)
- **System Frequency:** 59.94 Hz, 50.00 Hz
- **Frame Rate**
59.94 Hz: 59.94P, 59.94i², 29.97P, 23.98P
50.00 Hz: 50.00P, 50.00i², 25.00P
² Only when the resolution is 1920x1080.
- **Exposure:** AE shift, light metering modes (standard, spotlight, backlight)
- **White Balance**
Automatic white balance, custom white balance (two sets, A and B); color temperature setting (2,000 K to 15,000 K); two preset settings (daylight, 5,500 K³ and incandescent lamp, 3,000 K³)
³ Color temperatures are approximate and given for reference purposes only.
- **Iris:** Manual, push auto iris, automatic aperture (linked with gain, shutter speed and ND filter)
- **Gain:** 0.0 dB to 75.0 dB (3.0-dB increments)
- **Shutter speed:** 1/3 to 1/2000 (specific values depend on the system frequency and frame rate)
- **Optical filters**
ND filter: Built-in (two density levels: 1/8 or 1/64 the amount of light)
Infrared-cut filter: Motor operated
- **Focus:** Manual focus, one-shot AF
- **Lens Correction**
Peripheral illumination correction is available for Canon EF lenses⁴
⁴ Some Canon EF lenses are not compatible with in-camera correction.
- **Gamma:** Normal (four types), EOS Std., Wide DR, Canon Log

Terminals

- **3G/HD-SDI 1 / MONITOR and 3G/HD-SDI 2 Terminals**
 BNC jack, output only, 0.8 Vp-p / 75 Ω , unbalanced; onscreen displays can also be output⁵
 3G-SDI: SMPTE 424, SMPTE 425, SMPTE ST 299-2
 HD-SDI: SMPTE 292, SMPTE ST 299-1
⁵3G/HD-SDI 1 / MONITOR terminal only.
- **HDMI OUT Terminal**
 Type A, output only
 1080P/1080i/720P/576P⁶/480P⁶
⁶A 480P/576P video signal is output only when a monitor that supports only 480P/576P is connected to the camera.
- **MIC Terminal**
 \varnothing 3.5 mm stereo mini-jack (can supply power to a plug-in power microphone)
 Supplied power: 2.8 V DC (bias resistance 2.2 k Ω)
- **GENLOCK Terminal**
 BNC jack, input only, 1.0 Vp-p / 75 Ω
- **REMOTE A and REMOTE B Terminals**
 REMOTE A: \varnothing 2.5 mm stereo mini-mini-jack
 REMOTE B: Circular 8-pin jack (for RS-422)
- **LENS terminal**
 12-pin serial connection (Currently, not yet available for use. Lens operational control will be made available in a future firmware update.)

Power/Others

- **Power Supply:** Input range of 11 to 17 V DC
- **Power Consumption (camera body only):** Approx. 12 W
- **Operating Temperature**
 0 – 40 °C (32 – 104 °F)
- **Dimensions (W x H x D, excluding protrusions)**
 Approx. 102 x 116 x 113 mm (4.0 x 4.6 x 4.4 in.)
- **Weight (camera body only):** 1,100 g (2.4 lb.)

Weight and dimensions are approximate. Errors and omissions excepted.

The information in this manual is verified as of October 2015. Subject to change without notice.

Appendix

Physical Measurements

Back view

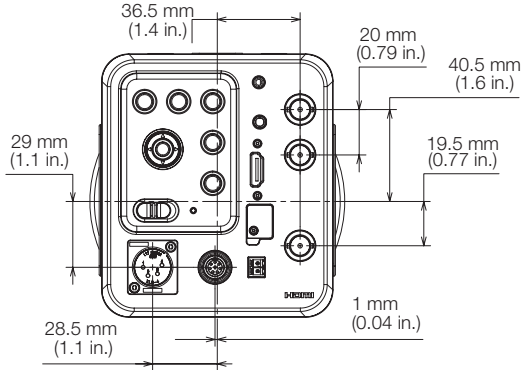

Front view

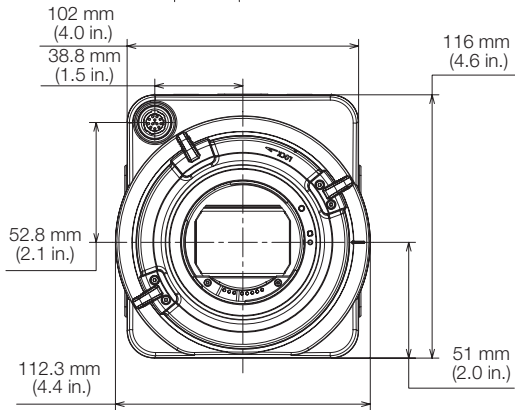

Top view

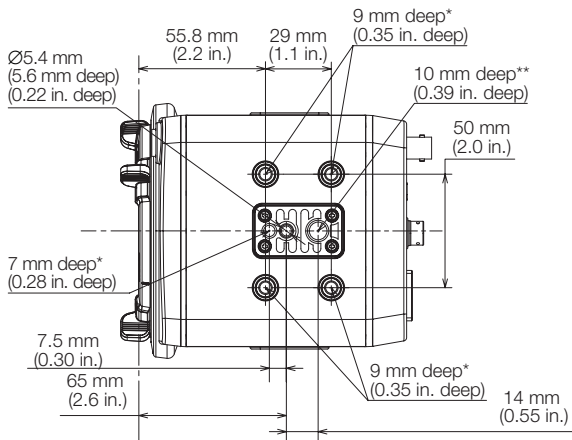

Bottom view

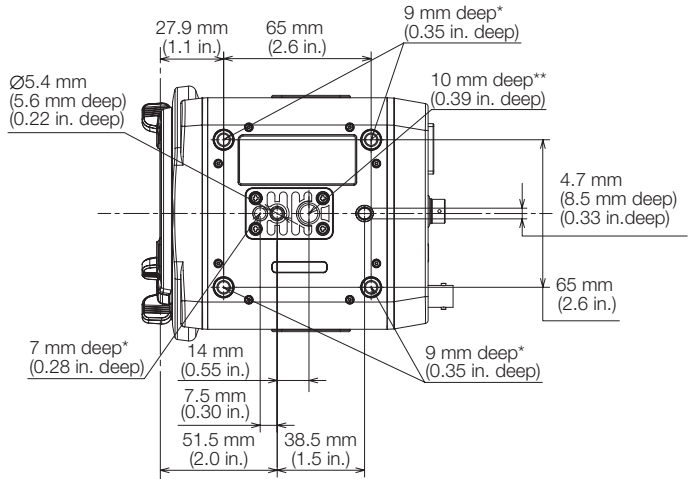

Right side view

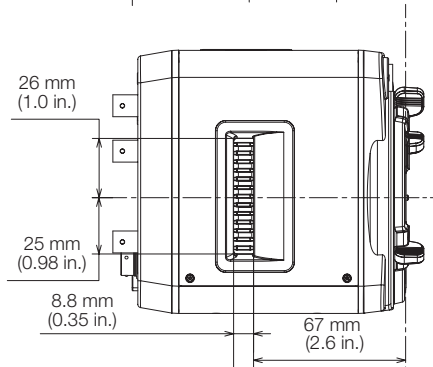

Left side view

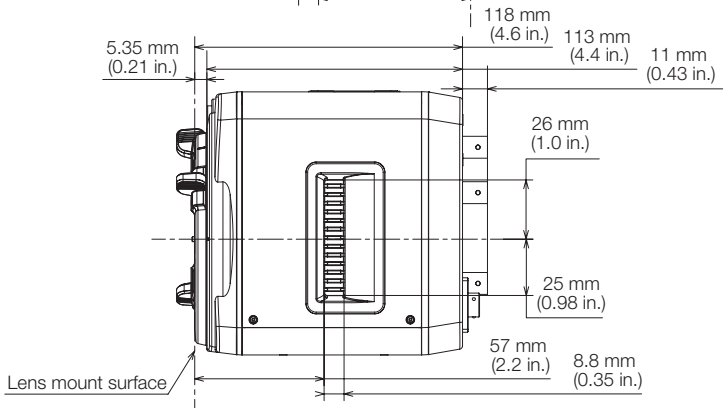

* Socket for 0.64 cm (1/4 in.) screws.

** Socket for 0.95 cm (3/8 in.) screws.

Index

A	
ABB (automatic black balance)	22
Accessories	67
Adjusting main camera functions with the joystick	32
AE shift	35
AGC limit	37
Aperture	34
Push auto iris	34
Assignable buttons	48
Audio input and output	58
Audio reference signal	28
AWB (auto white balance)	40
B	
Black balance	22
C	
Camera mode	33
Canon Log	50
Color bars	28
Condensation	66
Connecting to an external monitor	18
Connecting to an external recorder	55
Controlling an external recorder	55
Custom display	28, 54
Custom picture	50
D	
Date and time settings	19
DC IN 1 and DC IN 2 terminals	16
E	
EF lens mount	22
EOS standard	51
Exposure compensation	35
F	
Fan	62
Flicker reduction	38
Focus	43
Focus limit	44
One-shot AF	43
Frame rate	31
G	
Gain	37
GENLOCK terminal	57
H	
HDMI OUT terminal	18, 55
Hour meter	64
I	
Infrared mode	46
Iris	34
J	
Joystick	20
L	
Lens	22
Light metering mode	35
M	
Menu settings	59
MIC terminal	58
Microphone (external)	58
Monitor (external)	18
N	
ND filter	39
O	
Onscreen displays	28
P	
Peripheral illumination correction	24
Power supply	16
POWER switch	17
R	
Recorder (external)	55
Recording command	55
REMOTE terminal	47
Resetting all camera settings	62
Resolution	31
S	
Shooting video	27
Shutter speed	38
Specifications	68
Synchronization	57
System frequency	31
T	
Tripod	26

Turning the camera on/off 17

U

Using the optional RC-V100
Remote Controller 47

V

Video configuration 31

W

White balance 40
Wide DR 51

CANON MULTI-PURPOSE CAMERA EQUIPMENT LIMITED WARRANTY FOR PRODUCTS PURCHASED IN THE UNITED STATES

The Limited Warranty set forth below is given by Canon U.S.A., Inc. ("Canon USA") with respect to the Canon multi-purpose camera (the "Product") when purchased and used in the United States. This Limited Warranty is only effective upon presentation of your Bill of Sale or other proof of purchase. The Product, when delivered in new condition in its original container, is warranted to the original end-user purchaser, under normal use against defective materials or workmanship as follows: Parts: for a period of one (1) year from the date of original purchase, defective parts or defective Products returned to Canon USA or its designated Factory Service Center in the United States, and proven to be defective upon inspection, will be repaired with new or comparable rebuilt parts or exchanged for refurbished Products, as determined by Canon USA or its designated Factory Service Center. Labor: for a period of one (1) year from the date of original purchase, labor will be provided free of charge by Canon USA's designated Factory Service Center. When returning the Product under this warranty, you must pre-pay the shipping charges and enclose a copy of the Bill of Sale or other proof of purchase with a complete explanation of the problem. During the one (1) year warranty period, repairs will be made and the Product will be return-shipped to you free of charge. For repairs after the warranty period is over, you will be given an estimate of the cost of repair and an opportunity to approve or disapprove of the repair expense before it is incurred. If you approve, repairs will be made and the Product will be returned to you at your risk and expense. If you disapprove, we will return-ship the Product to you at no charge to you to an address within the United States.

Canon USA will have no responsibility under this Limited Warranty for use of the Product in conjunction with any accessories or peripheral equipment, and/or with any software, that may be used with the Product. The sole warranty, if any, with the respect to any other accessories, peripheral equipment and/or software that may be used with the Product is given by the manufacturer, licensor, or producer thereof.

In order to obtain warranty service, please contact the CANON INFORMATION CENTER AT 800-OK-CANON (800-652-2666) or on the Internet at pro.usa.canon.com/support. This Limited Warranty covers all defects encountered in normal use of the Product and does not apply in the following cases:

- (a) Loss or damage to the Product due to abuse, mishandling, accident, improper maintenance, improper packing by you, alteration, accident, electrical current fluctuations, use of non-Canon accessories, peripheral equipment and/or software (except for those genuine Canon-brand items expressly specified by Canon USA as compatible with the Product), or failure to follow operating, maintenance or environmental instructions prescribed in Canon user's manual;
- (b) Defects or damage caused by sand, dirt or water, or by service other than Canon USA's Factory Service Centers;
- (c) Use of parts or supplies (other than those sold by Canon USA) that cause damage to the Product or abnormally frequent service calls or service problems;
- (d) Products whose hardware or firmware has been modified;
- (e) Maintenance of the Product;
- (f) Products that have their serial number or dating altered or removed;
- (g) Damage or service resulting from modifications or alterations to a Product in any way;
- (h) Corrosion damage, or scratches, or abrasions;
- (i) Damage caused by dropping the Product.

NO IMPLIED WARRANTY, INCLUDING MERCHANTABILITY AND FITNESS FOR A PARTICULAR PURPOSE APPLIES TO THIS PRODUCT AFTER THE APPLICABLE PERIOD OF EXPRESS WARRANTY OR GUARANTY STATED ABOVE, AND NO OTHER EXPRESS WARRANTY OR GUARANTY (EXCEPT AS MENTIONED ABOVE) GIVEN BY ANY PERSON, FIRM OR CORPORATION WITH RESPECT TO THIS PRODUCT SHALL BIND CANON USA. CANON USA SHALL NOT BE LIABLE FOR LOSS OF REVENUES OR PROFITS, EXPENSE FOR SUBSTITUTE PRODUCT OR SERVICE, STORAGE CHARGES, LOSS OR CORRUPTION OF DATA, INCLUDING WITHOUT LIMITATION, LOSS OR CORRUPTION OF DATA STORED ON ANY PERIPHERAL DEVICE OR ACCESSORY SUCH AS, FOR EXAMPLE, A RECORDING DEVICE ATTACHED TO THE PRODUCT, OR ANY OTHER SPECIAL, INCIDENTAL OR CONSEQUENTIAL DAMAGES CAUSED BY THE

USE, MISUSE OR INABILITY TO USE THE PRODUCT, REGARDLESS OF THE LEGAL THEORY ON WHICH THE CLAIM IS BASED, AND EVEN IF CANON USA HAS BEEN ADVISED OF THE POSSIBILITY OF SUCH DAMAGES. NOR SHALL RECOVERY OF ANY KIND AGAINST CANON USA BE GREATER THAN THE PURCHASE PRICE OF THE PRODUCT SOLD BY CANON USA AND CAUSING THE ALLEGED DAMAGE. WITHOUT LIMITING THE FOREGOING, YOU ASSUME ALL RISK AND LIABILITY FOR LOSS, DAMAGE OR INJURY TO YOU AND YOUR PROPERTY AND TO OTHERS AND THEIR PROPERTY ARISING OUT OF USE, MISUSE OR INABILITY TO USE THE PRODUCT NOT CAUSED DIRECTLY BY THE NEGLIGENCE OF CANON USA. THIS WARRANTY SHALL NOT EXTEND TO ANYONE OTHER THAN THE ORIGINAL PURCHASER OF THIS PRODUCT OR THE PERSON FOR WHOM IT WAS PURCHASED AS A GIFT, AND STATES YOUR EXCLUSIVE REMEDY.

Canon U.S.A., Inc.

CANON MULTI-PURPOSE CAMERA EQUIPMENT LIMITED WARRANTY FOR PRODUCTS PURCHASED IN CANADA

The Limited Warranty set forth below is given by Canon Canada Inc. ("Canon Canada") with respect to the Canon multi-purpose camera (the "Product") when purchased and used in Canada. This Limited Warranty is only effective upon presentation of your Bill of Sale or other proof of purchase. The Product, when delivered in new condition in its original container, is warranted to the original end-user purchaser, under normal use against defective materials or workmanship as follows: Parts: for a period of one(1) year from the date of original purchase, defective parts or defective Products returned to Canon Canada or its designated Factory Service Centre in Canada, and proven to be defective upon inspection, will be repaired with new or comparable rebuilt parts or exchanged for refurbished Products, as determined by Canon Canada or its designated Factory Service Centre. Labour: for a period of one (1) year from the date of original purchase, labour will be provided free of charge by Canon Canada's designated Factory Service Centre. When returning the Product under this warranty, you must pre-pay the shipping charges and enclose a copy of the Bill of Sale or other proof of purchase with a complete explanation of the problem. During the one (1) year warranty period, repairs will be made and the Product will be return-shipped to you free of charge. For repairs after the warranty period is over, you will be given an estimate of the cost of repair and an opportunity to approve or disapprove of the repair expense before it is incurred. If you approve, repairs will be made and the Product will be returned to you at your risk and expense. If you disapprove, we will return-ship the Product to you at no charge to you to an address within Canada.

Canon Canada will have no responsibility under this Limited Warranty for use of the Product in conjunction with any accessories or peripheral equipment, and/or with any software, that may be used with the Product. The sole warranty, if any, with the respect to any other accessories, peripheral equipment and/or software that may be used with the Product is given by the manufacturer, licensor, or producer thereof.

In order to obtain warranty service, please contact the CANON INFORMATION CENTRE AT 800-OK-CANON (800-652-2666) or on the Internet at canon.ca/support. This Limited Warranty covers all defects encountered in normal use of the Product and does not apply in the following cases:

- (a) Loss or damage to the Product due to abuse, mishandling, accident, improper maintenance, improper packing by you, alteration, accident, electrical current fluctuations, use of non-Canon accessories, peripheral equipment and/or software (except for those genuine Canon-brand items expressly specified by Canon Canada as compatible with the Product), or failure to follow operating, maintenance or environmental instructions prescribed in Canon user's manual;
- (b) Defects or damage caused by sand, dirt or water, or by service other than Canon Canada's Factory Service Centres;
- (c) Use of parts or supplies (other than those sold by Canon Canada) that cause damage to the Product or abnormally frequent service calls or service problems;
- (d) Products whose hardware or firmware has been modified;
- (e) Maintenance of the Product;
- (f) Products that have their serial number or dating altered or removed;
- (g) Damage or service resulting from modifications or alterations to a Product in any way;
- (h) Corrosion damage, or scratches, or abrasions;
- (i) Damage caused by dropping the Product.

NO IMPLIED WARRANTY OR CONDITION, INCLUDING MERCHANTABILITY AND FITNESS FOR A PARTICULAR PURPOSE APPLIES TO THIS PRODUCT AFTER THE APPLICABLE PERIOD OF EXPRESS WARRANTY, CONDITION OR GUARANTY STATED ABOVE, AND NO OTHER EXPRESS WARRANTY, CONDITION OR GUARANTY (EXCEPT AS MENTIONED ABOVE) GIVEN BY ANY PERSON, FIRM OR CORPORATION WITH RESPECT TO THIS PRODUCT SHALL BIND CANON CANADA. CANON CANADA SHALL NOT BE LIABLE FOR LOSS OF REVENUES OR PROFITS, EXPENSE FOR SUBSTITUTE PRODUCT OR SERVICE, STORAGE CHARGES, LOSS OR CORRUPTION OF DATA, INCLUDING WITHOUT LIMITATION, LOSS OR CORRUPTION OF DATA STORED ON ANY PERIPHERAL DEVICE OR ACCESSORY SUCH AS, FOR EXAMPLE, A

RECORDING DEVICE ATTACHED TO THE PRODUCT, OR ANY OTHER SPECIAL, INCIDENTAL OR CONSEQUENTIAL DAMAGES CAUSED BY THE USE, MISUSE OR INABILITY TO USE THE PRODUCT, REGARDLESS OF THE LEGAL THEORY ON WHICH THE CLAIM IS BASED, AND EVEN IF CANON CANADA HAS BEEN ADVISED OF THE POSSIBILITY OF SUCH DAMAGES. NOR SHALL RECOVERY OF ANY KIND AGAINST CANON CANADA BE GREATER THAN THE PURCHASE PRICE OF THE PRODUCT SOLD BY CANON CANADA AND CAUSING THE ALLEGED DAMAGE. WITHOUT LIMITING THE FOREGOING, YOU ASSUME ALL RISK AND LIABILITY FOR LOSS, DAMAGE OR INJURY TO YOU AND YOUR PROPERTY AND TO OTHERS AND THEIR PROPERTY ARISING OUT OF USE, MISUSE OR INABILITY TO USE THE PRODUCT NOT CAUSED DIRECTLY BY THE NEGLIGENCE OF CANON CANADA. THIS WARRANTY SHALL NOT EXTEND TO ANYONE OTHER THAN THE ORIGINAL PURCHASER OF THIS PRODUCT OR THE PERSON FOR WHOM IT WAS PURCHASED AS A GIFT, AND STATES YOUR EXCLUSIVE REMEDY.

Canon Canada Inc.

Canon

Canon Inc. 30-2, Shimomaruko 3-chome, Ohta-ku, Tokyo 146-8501, Japan
CANON Europa N.V. Bovenkerkerweg 59, 1185 XB Amstelveen, The Netherlands
<http://www.canon-europe.com>

ASIA and HONG KONG, S.A.R.

Canon Hongkong Company Ltd
19/F, The Metropolis Tower, 10 Metropolis
Drive, Hunghom, Kowloon, Hong Kong
☎ +852 3191 2333, ☎ +852 2428 3963

AUSTRALIA <http://www.canon.com.au>

Canon Australia Pty Ltd
☎ 13-13-83 (within Australia only)
☎ (61) 02-9805-2555

BELGIQUE <http://www.canon.be>

Canon Belgium NV/SA
Berkenlaan 3, 1831 Diegem (Machelen)
☎ (02) 722 0411 ☎ (02) 721 3274

CANADA

CANON CANADA INC.
6390 Dixie Road, Mississauga, ON L5T 1P7

❖ If you have any questions, call the Canon
Canada Information Center toll free (in
Canada only) at 1-800-OK-CANON
(1-800-652-2666).

❖ Si vous avez des questions, veuillez
téléphoner 1-800-OK-CANON
(1-800-652-2666, sans frais au Canada
seulement).

CENTRO Y SURAMÉRICA

<http://www.cla.canon.com>
CANON LATIN AMERICA, INC.

FRANCE <http://www.canon.fr>

Canon France SAS, Canon
Communication & Image
17, Quai du Président Paul Doumer, 92414
Courbevoie CEDEX ☎ (01) 41 30 15 15

LUXEMBOURG <http://www.canon.lu>

Canon Luxembourg SA
Rue des joncs, 21, L-1818 Howald
☎ (352) 48 47 961

MÉXICO <http://www.canon.com.mx>

CANON MEXICANA, S DE RL DE CV
☎ 52 (55) 5249-4905

NEW ZEALAND <http://www.canon.co.nz>

Canon New Zealand Ltd
☎ 0800-222-666 (within New Zealand only)
☎ (64) 09-489-0300

ÖSTERREICH <http://www.canon.at>

Canon Austria GmbH
Oberlaaer Straße 233 A-1100 Wien
Canon Helpdesk: ☎ 0810 0810 09 (zum Ortstarif)

SINGAPORE

Canon Singapore Pte. Ltd
1 Fusionopolis Place, #15-10 Galaxis,
Singapore 138522
☎ (65) 6799 8888, ☎ (65) 6799 8882

SUISSE/SCHWEIZ <http://www.canon.ch>

Canon (Schweiz) AG
Industriestrasse 12 CH-8305 Dietlikon
Canon Helpdesk: ☎ 0848 833 838

UNITED KINGDOM

Canon UK Ltd
CCI Service Centre, Unit 130, Centennial
Park, Borehamwood, Hertfordshire, WD6 3SE
☎ 0844-369-0100

USA

CANON U.S.A., INC. NEW JERSEY OFFICE
100 Jamesburg Road, Jamesburg,
NJ 08831 USA

CANON U.S.A., INC. CHICAGO OFFICE
100 Park Blvd., Itasca, IL 60143 USA

CANON U.S.A., INC. LOS ANGELES OFFICE
15955 Alton Parkway, Irvine, CA 92618 USA

CANON U.S.A., INC. HONOLULU OFFICE
210 Ward Avenue, Suite 200, Honolulu,
HI 96814 USA

❖ If you have any questions, call the Canon
U.S.A. Information Center toll-free at
1-800-828-4040 (USA only).

- Visit your local Canon Web site to download the latest version of this Instruction Manual.
- Consultez le site Web Canon de votre pays pour télécharger la version la plus récente de ce mode d'emploi.



D I M 1 1 4 1 0 0 0